

# Logix Magnum IT and Cv Valves

Installation and Service Manual





---

---

## Table Of Contents

1.0	Installation Profile Summary	3
2.0	Introduction to the Logix Magnum Cv and Magnum IT Valve Series	4
2.1	Assembling the Control to the Magnum Valve	5
2.2	Magnum General Specifications	9
2.3	Magnum Cv Dimensional Specifications	10
3.0	General Installation Information	12
3.1	Typical Installation Drawings	14
4.0	Flow Diagrams	15
5.0	Identifying the Logix Control: 742/742F Time Clock or 762/762F Demand and Magnum Valve	20
6.0	General Logix Series Instructions	21
7.0	742/762 Series Initial Power-Up	23
8.0	Initial Programming Instructions	24
	Logix Magnum Time Clock 742/298 - 5-Cycle Conditioner	25
	Logix Magnum Demand 762/298 - 5-Cycle Conditioner	26
	Logix Magnum Time Clock 742F/293 - 3-Cycle Filter	27
	Logix Magnum Demand 762F/293 - 3-Cycle Filter	28
9.0	Regeneration Modes	30
10.0	Placing Conditioner into Operation (turning on the water)	31
11.0	Programming the Logix for Manganese Greensand Systems	33
11.1	Special Applications — How to Program the 742/762	34
12.0	Things You Might Need to Know	35
13.0	742/762 Level II Programming	36
14.0	Cycle Time Programming	41
15.0	Accessing History Values	42
16.0	Control Reset	43
17.0	Troubleshooting	44
17.1	Troubleshooting: Logix Controller	44
17.2	Troubleshooting: Magnum IT and Cv Valve	45
18.0	Magnum Valve Cartridge Removal Procedure	48
19.0	Performance Injectors	49
19.1	Injector Charts	49
19.2	Magnum Injector Controls	51

---

---

20.0	Magnum Flow Controls .....	52
20.1	Refill Control Identification .....	52
20.2	Drain Line Flow Control .....	53
20.3	Recommended Backwash Flow Rates for Various Media .....	54
20.4	Logix Magnum It and Cv Exploded View .....	55
21.0	Replacement Components: Logix Magnum Conditioner/Filters .....	56
21.1	Camshaft and Pilot Valve Assembly .....	56
21.2	Camshaft Components .....	56
21.3	Magnum Valve Cartridges .....	57
21.4	Injector Assembly .....	58
21.5	Refill Flow Control Assembly .....	59
21.6	Magnum IT Flow Sensor Assembly .....	60
21.7	Installation Adapter Kits .....	61
21.8	Miscellaneous Kits and Assemblies .....	63
	.....	63



---

---

## 1.0 Installation Profile Summary

Installation Date: \_\_\_\_\_

Installation Location: \_\_\_\_\_

Installer(s): \_\_\_\_\_

Phone Number: \_\_\_\_\_

Valve Number: \_\_\_\_\_

Application Type: (Softener) (Filter) (Dealkalizer)

### Water Source:

(Public Well) (Private Well)

(Surface Supply)

(Other)

### Water Test Results:

Hardness: \_\_\_\_\_ Iron: \_\_\_\_\_

Other: \_\_\_\_\_

### Misc:

Capacity: \_\_\_\_\_ Flow Rates: \_\_\_\_\_ min. \_\_\_\_\_ max.

Tank Size: Diameter \_\_\_\_\_ Height: \_\_\_\_\_

Resin or Media Volume: \_\_\_\_\_

Resin or Media Type: \_\_\_\_\_

Brine Tank Volume: \_\_\_\_\_

Salt Setting per Regeneration: \_\_\_\_\_

### Control Valve Configuration:

Valve Type: \_\_\_\_\_

(Hard Water Bypass) (No Hard Water Bypass)

Refill Control: \_\_\_\_\_ gpm

Injector Control: \_\_\_\_\_ gpm

Backwash Control: \_\_\_\_\_ gpm

### Electronic Demand Settings

P1 Time of day \_\_\_\_\_

P2 Day of week \_\_\_\_\_

P3 Time of regeneration \_\_\_\_\_

P4 Number of days between regeneration (99 day calendar override) \_\_\_\_\_

P5 (742 only) Day of week regeneration \_\_\_\_\_

### Regeneration Frequency:

S M T W T F S

1 2 3 4 5 6 7

P6 Amount of regenerant used per regeneration or filter backwash time (salt setting) \_\_\_\_\_

P7 System capacity \_\_\_\_\_

P8 Hardness \_\_\_\_\_

P9 Units of measure \_\_\_\_\_

P10 Clock mode \_\_\_\_\_

P11 Service interval \_\_\_\_\_

P12 Remote regeneration switch delay \_\_\_\_\_

P13 Refill sensor control (conditioner only) \_\_\_\_\_

0 = Off

1 = Salt detector only

2 = Chlorine generation

P14 Refill rate (conditioner only) \_\_\_\_\_

P15 Draw rate (conditioner only) \_\_\_\_\_

P16 Reserve type \_\_\_\_\_

P17 Initial average or fixed reserve \_\_\_\_\_

P18 Flow sensor select \_\_\_\_\_

P19 K-factor or pulse equivalent \_\_\_\_\_

## 2.0 Introduction to the Logix Magnum Cv and Magnum IT Valve Series

The Magnum Cv™ and Magnum IT™ Series valves offer a high degree of installation simplicity and flexibility. Figure 2.1 provides an overview of the major components and connections of the 2-inch (5.08-cm) Magnum IT valve.

The Magnum valve is available in either a 1-1/2-inch (3.81-cm) Magnum Cv™ or a 2-inch (5.08-cm) Magnum IT™ configuration. Throughout this manual, the 2-inch (5.08-cm) Magnum Cv is shown in illustrations where the model type is irrelevant to what is being demonstrated.

### Magnum IT™ Series Valve

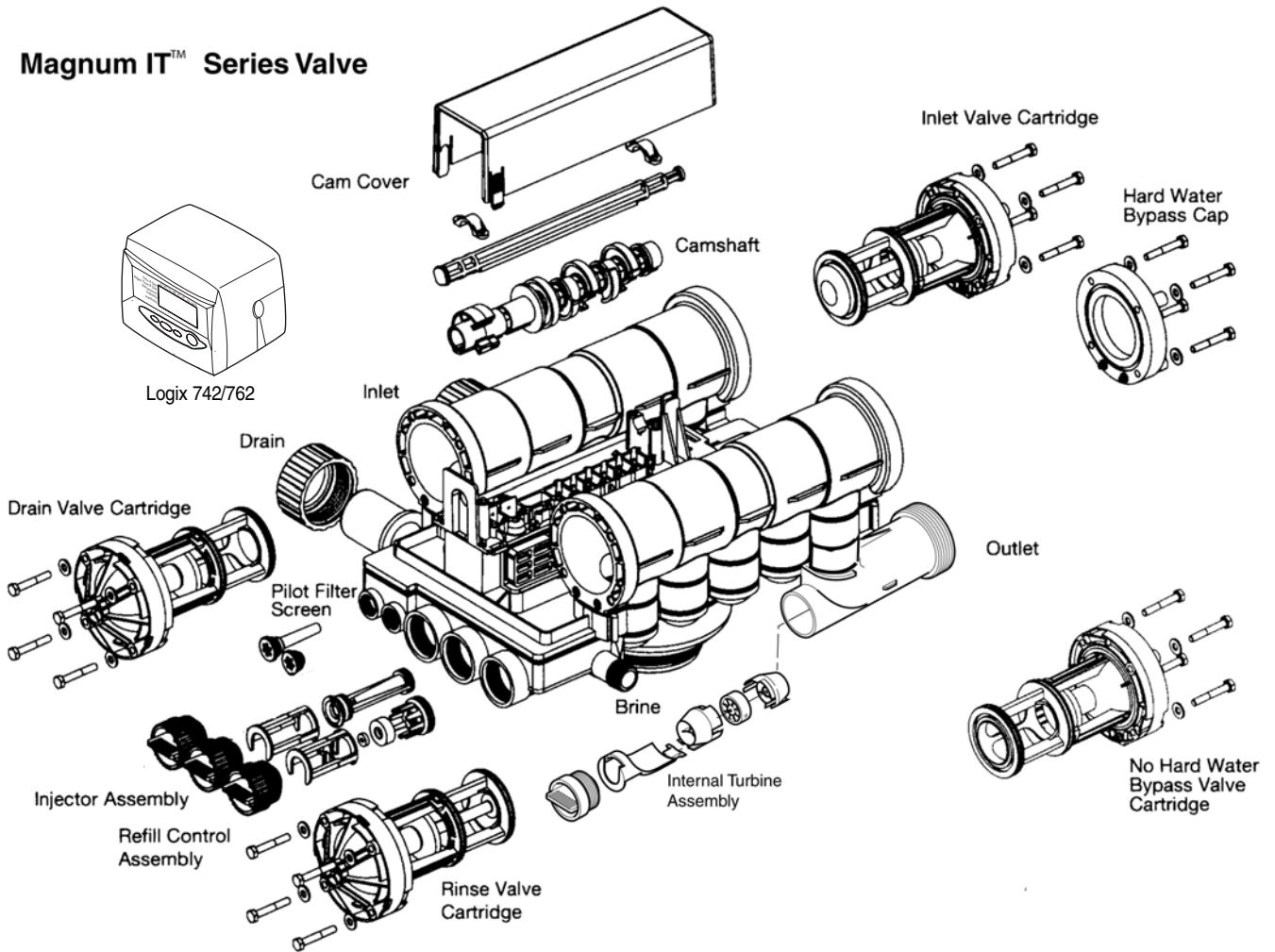

Figure 2.1

## 2.1 Assembling the Control to the Magnum Valve

The control and the Magnum valve work together as an integral system to ensure synchronization. Follow the steps outlined below to install the control on the Magnum valve.

### Remove Cam Cover

Remove the cam cover by pressing in on the cover release tabs (Figure 2.2). Note the cover locking tab and the slot in the top plate. When you reassemble the cover, the locking tab is placed in the slot first and the cover lowered into position.

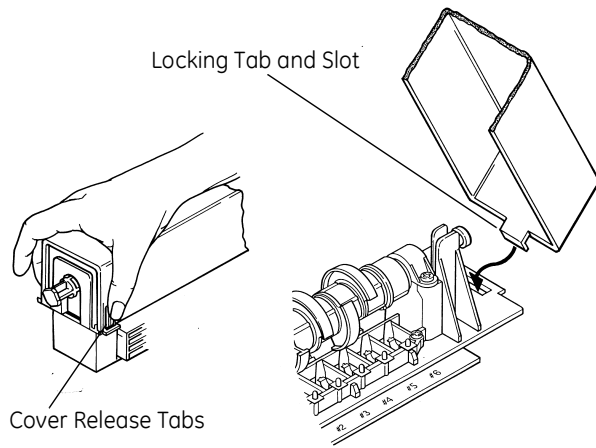

Figure 2.2

### Align Camshaft

The camshaft is keyed and should only be engaged or disengaged when in the position illustrated (Figure 2.3). If the camshaft is not in the proper position, rotate the cam assembly counterclockwise until the camshaft arrow aligns with pillow block arrow.

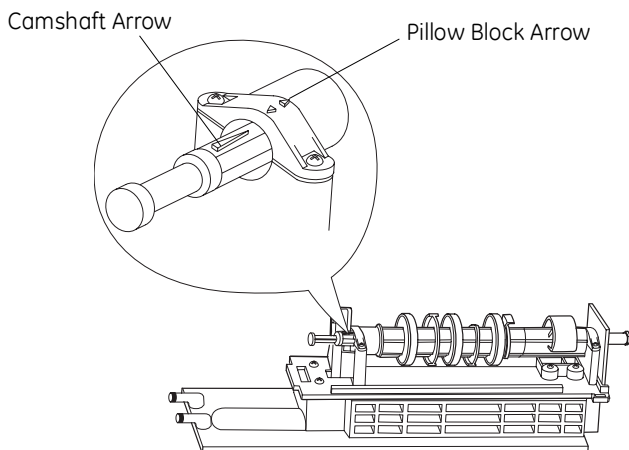

Figure 2.3

### Slide Camshaft

Slide the camshaft toward the back of the valve by pressing on the release tab and pulling on the back end of the camshaft (Figure 2.4). The front end of the camshaft will be flush with the mounting plate.

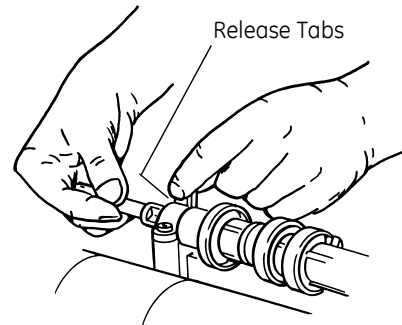

Figure 2.4

### Mount Control

Mount the control onto the valve by sliding the mounting tabs over the mounting plate. Note that all models of Magnum controls mount to the valve in the same manner (Figure 2.5).

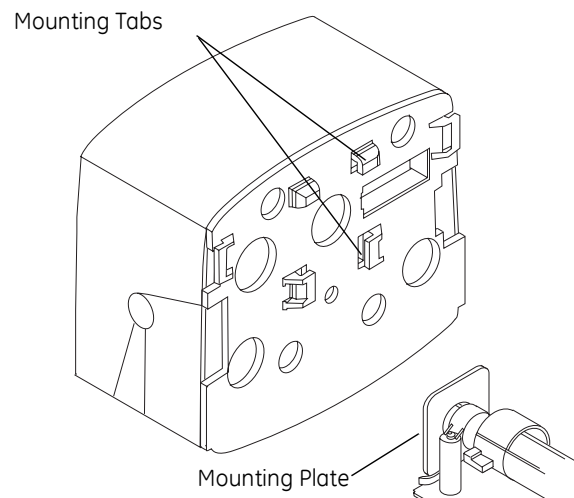

Figure 2.5

### Engage Assembly

The camshaft will not rotate by hand when engaged with the controller. The Logix Magnum controller contains a motor with gears that drive a socket. The camshaft is keyed to only properly engage the socket when the Logix controller is in the treated water (Home) position. Refer to Section 7 for instructions on rotating the camshaft.

If the camshaft is pulled back and not engaged it can be rotated counterclockwise. Rotate the camshaft to align the arrows (Figure 2.3). If the Logix Magnum controller is

not in the treated water position, cycling the power will cause the socket to rotate to that position.

Engage the control by pressing on the release tab and pushing the camshaft into the control (Figure 2.6). Do not force the camshaft. If the camshaft does not slide freely into the control, check the alignment of the camshaft to the controller. Ensure it is in the proper position (Figure 2.3).

The Logix controller moves to the treated water (home) position when first power is applied. Refer to Section 7 for initial power up.

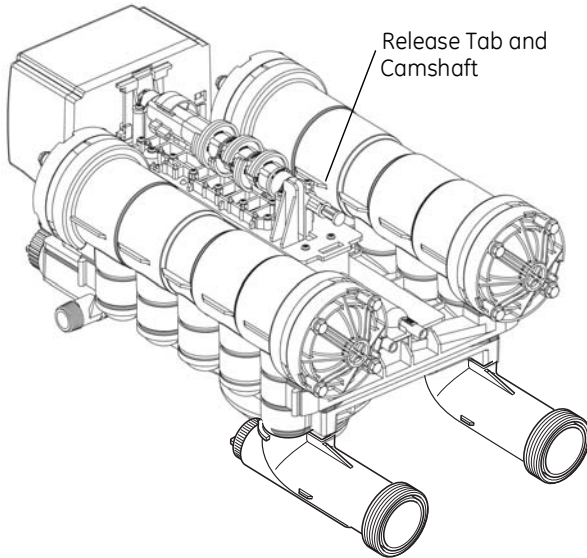

Figure 2.6

To disassemble the control from the valve, reverse the assembling procedure.

**Inlet, Outlet and Drain Connections**

The inlet, outlet, and drain connections are designed to accept a GE Water Technologies supplied CPVC or brass adapter (Figure 2.7). The adapters provide a convenient union for the three connection ports on the valve. In addition, they incorporate a positive O-ring face seal for ease of installation and leak free operation. DO NOT OVERTIGHTEN THE ADAPTERS. As a general guideline, hand tightening the nut onto the valve is adequate. If additional tightening is required, never exceed a quarter turn beyond the hand tight position.

The outlet of the 2-inch Magnum IT has an integrated turbine. The turbine measures the flow of water through the outlet. This information is used by the controller to determine the best time to recycle.

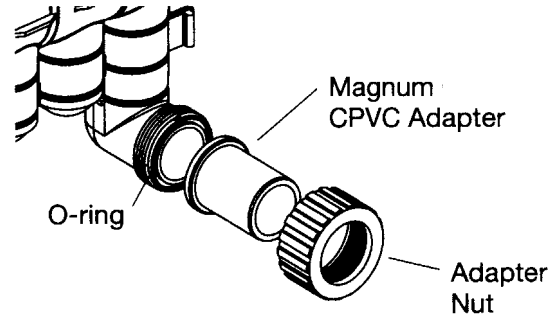

Figure 2.7

**No Hardwater Bypass Feature**

The Magnum control valve may be configured for “Hard Water Bypass” or “No Hard Water Bypass”. With Hard Water Bypass, unsoftened or unfiltered water is allowed to bypass the Magnum control valve during regeneration or backwash. With No Hard Water Bypass, a valve cartridge ensures that no unsoftened or unfiltered water bypasses the valve during regeneration or backwash.

It is easy to observe which option is installed in the valve. Note that the Hard Water Bypass End Cap has much longer standoffs than the No Hard Water Bypass cartridge. The No Hard Water Bypass assembly looks identical to the other three valve cartridges on the valve and has a label identifying the cartridge assembly (Figure 2.8).

*No Hard Water Bypass  
No Unfiltered Water Bypass*

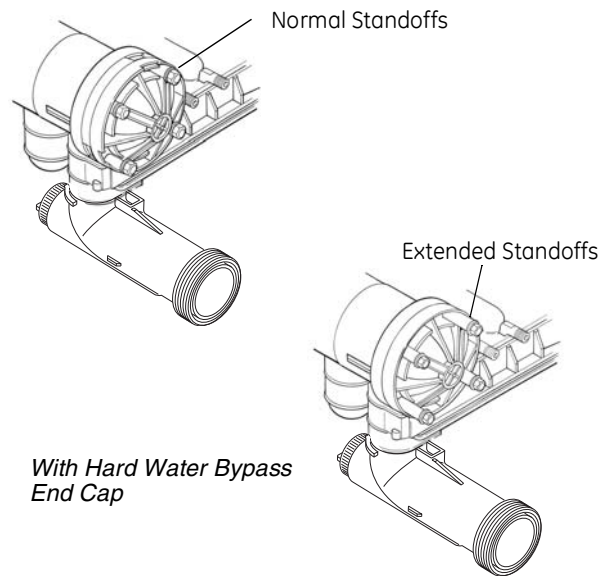

Figure 2.8

## Hydraulic Output Signal

An optional hydraulic output signal is available on the valve. An optional cam lobe on pilot valve #6 is used on the camshaft assembly to initiate the hydraulic output signal during regeneration or backwash (Figure 2.9). The hydraulic line pressure signal is available through the 1/4-inch connection on the back of the valve marked "AUX". See Figure 2.10. Remove the tube cap installed for shipping.

Optional cam lobes available are:

P/N 1000554 Provides a hydraulic signal from the beginning of BACKWASH through the start of REFILL.

P/N 1000553 Provides a hydraulic signal from the beginning of BACKWASH through the end of REFILL.

P/N 1041064 Breakaway cam. Can be programmed to send a hydraulic signal at any time during the REGENERATION or BACKWASH cycle. Note: The camshaft must be turning for the signal to change states, i.e. switch from OFF to ON, or from ON to OFF.

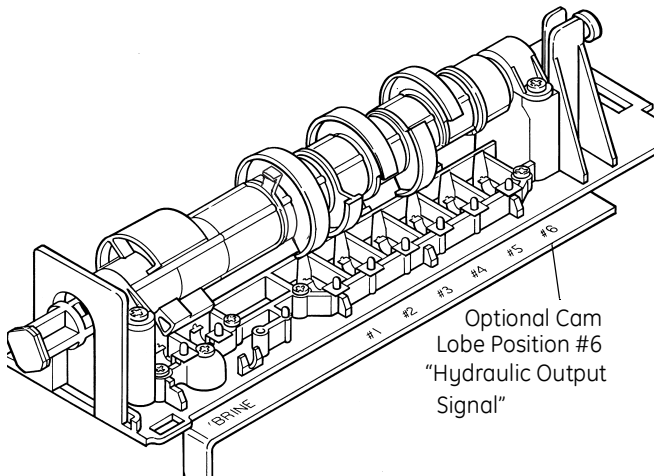

Figure 2.9

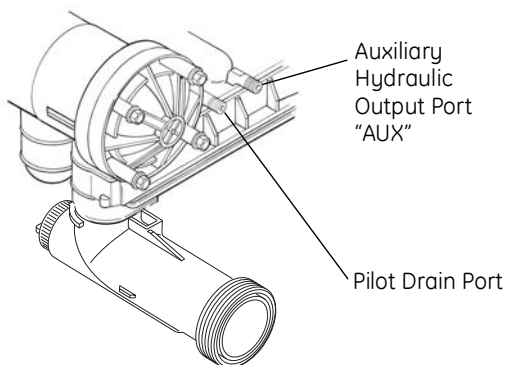

Figure 2.10

## Magnum Tank Adapter

The tank adapter on the control valve is designed to be compatible with a 4 inch-8UN (8 threads per inch) tank opening. In addition, the adapter is designed to accept a full 1-1/2-inch (3.81-cm) riser pipe with outside diameter of 1.90 to 1.91 inches (48.26 to 48.51 mm) (Figure 2.11). The riser pipe is sealed by an O-ring on the inside of the tank adapter (Figure 2.11). It is recommended that the riser pipe extend beyond the top of the tank by 1/4 inch  $\pm$  3/8 inch (6 mm  $\pm$  9 mm).

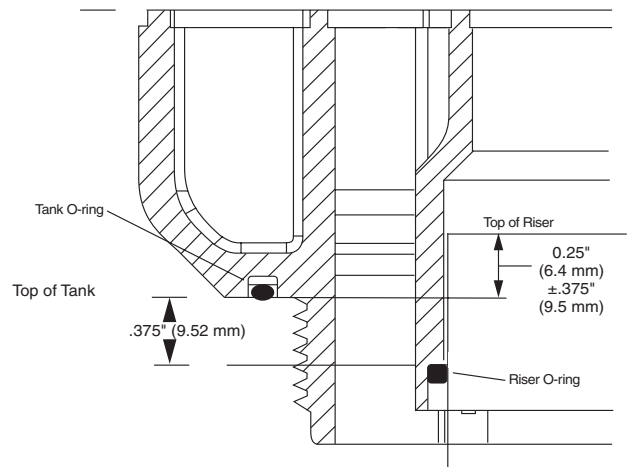

Figure 2.11

## Optional Switch Assembly

A single optional feedback switch kit is available to provide an electrical signal during the entire regeneration or backwash cycle (Figure 2.12). The switch may be wired in the "Normally Open" or "Normally Closed" position and is rated for 0.1 amp at 125 volts AC. An optional 5.0 amp switch at 1/10 HP 125/250 volts AC is available upon request.

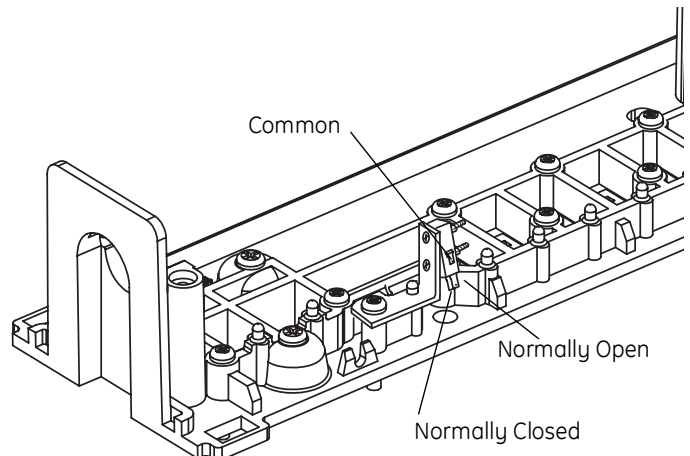

Figure 2.12

---

Optional multi-switch kits are available to provide additional electrical or switch closure signals during the regeneration or backwash cycles. Coupled with the optional breakaway cams, signals can be sent to external system equipment at virtually any time while the control/camshaft motor is running. Consult the instruction sheet covering the multi-switch option for additional application and programming information. The instruction sheet is sent with the switch kit.

---

---

## 2.2 Magnum General Specifications

### Operating and Environmental

Dynamic Pressure .....	25 to 100 psig (172 to 688 kPa)
	100 psig (688kPa) maximum in Canada
Operating Water Temperature Range.....	34 to 100°F (1 to 36°C)
Ambient Temperature Range.....	34 to 120°F (1 to 50°C)
Cap Bolt Torque .....	35 to 40 inch lbs. (3.95 to 4.51 N <sub>m</sub> )

### Connections

Inlet and Outlet.....	1-1/2 inch Magnum Cv
	2-inch Magnum IT
Tank.....	4-inch 8UN
Brine.....	3/4-inch NPT
Pilot Drain and Auxiliary Hydraulic Out.....	1/4-inch tube fitting
Riser Pipe Fitting.....	1-1/2 inch (3.81-cm)
Drain .....	1-1/2 inch (3.81-cm)

### Physical

Dimensions .....	Refer to drawings on pages 9 and 10
Approximate Weight (Valve and Control) .....	23.3 lbs. (10.6 kg.)

### Electrical\*

Voltage - Logix 742/762 Series Control.....	12 VAC wall mount transformer only
Power Consumption.....	4 watts

\*See section on Electronic Controls for alternative electrical configurations.

## 2.3 Magnum Cv Dimensional Specifications

### 1 1/2-inch Inlet, Outlet and Drain

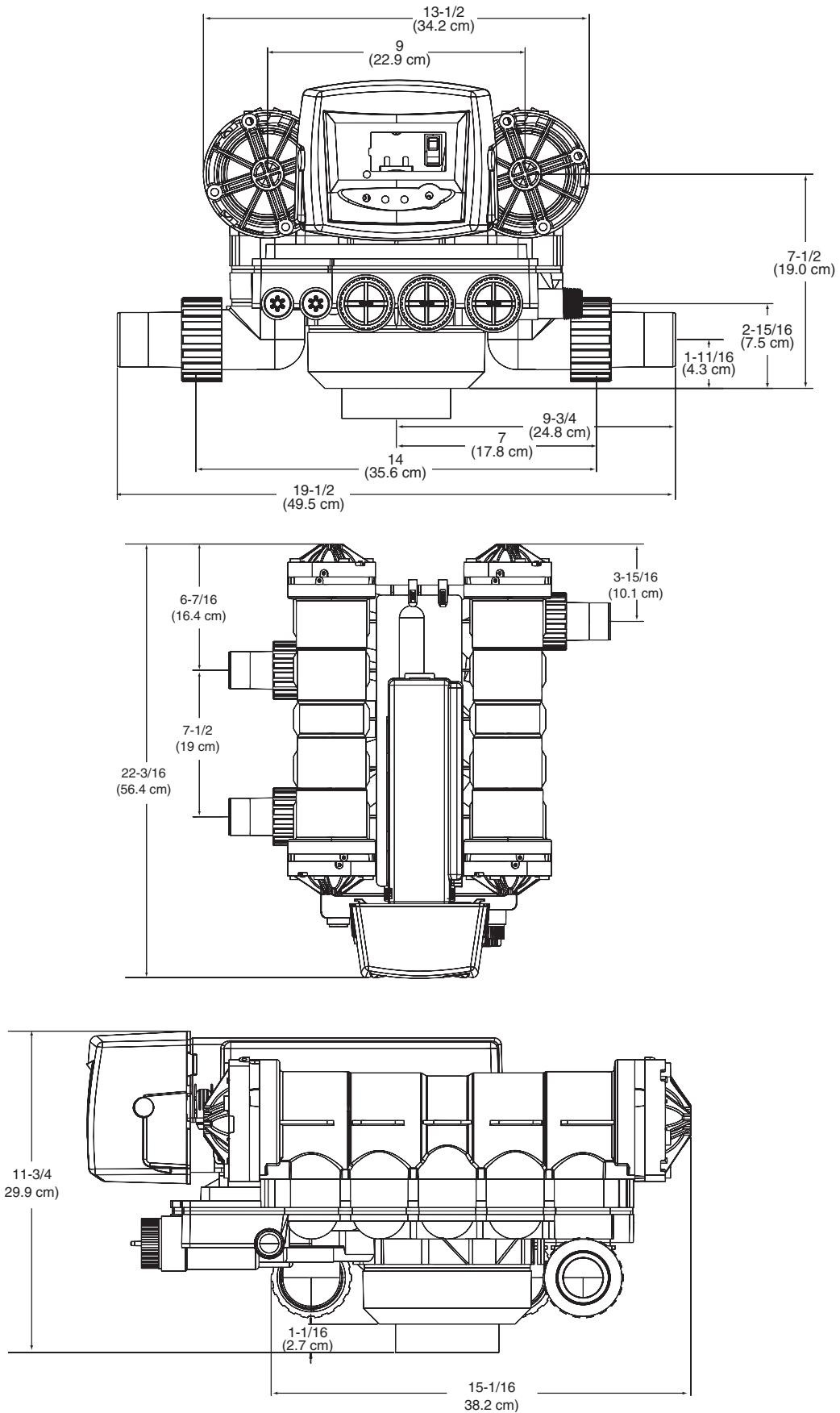



## 2.4 Magnum IT Dimensional Specifications

### 2-Inch Inlet and Outlet, 1 1/2-Inch Drain

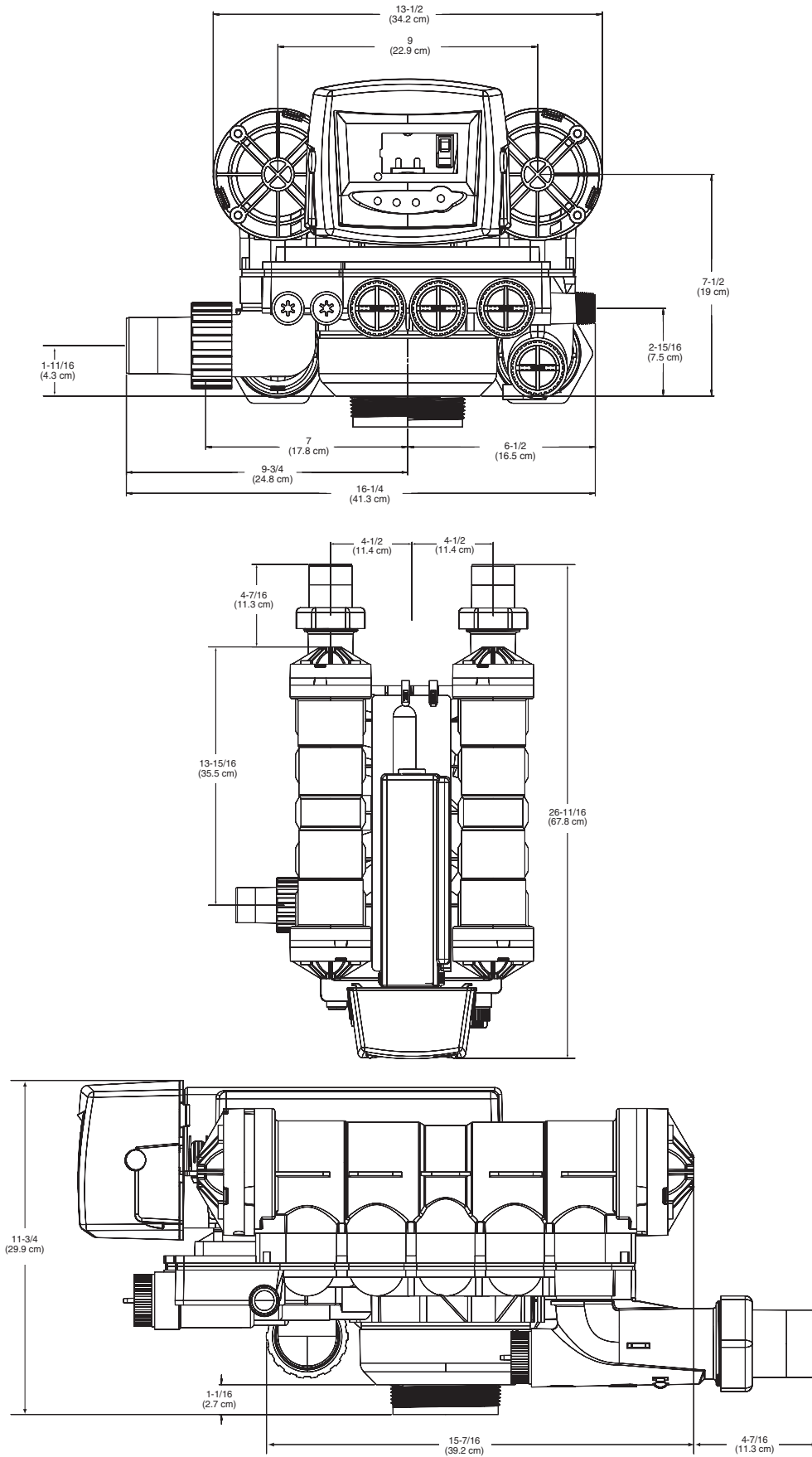

---

---

### 3.0 General Installation Information

Please review the following items thoroughly to ensure an efficient and safe installation of the water treatment system. The typical installation line drawings for the Magnum valves are shown on page 14.

**Operating Conditions - A minimum dynamic operating water pressure of 25 psig (172 kPa) is required for the Magnum control valve to operate properly.** Water pressure is not to exceed 125 psig (862 kPa). In Canada, water pressure is not to exceed 100 psig (688 kPa). Water temperature is not to exceed 100°F (36°C). Do not subject the valve to freezing conditions.

**Space Requirements -** Allow adequate space for the water treatment system and associated piping. The **General Specifications** section (page 9) provides the overall dimensions of the control valve as well as the dimensional reference information for each of the connection ports. A minimum of 4 1/2 inches (11.5 cm) front and rear clearance is required for cartridge assembly and removal.

**Plumbing -** Always follow good plumbing practices and conform to local codes. Check existing pipes for lime and/or iron buildup. Replace piping if heavy buildup exists and initiate the proper treatment to prevent additional occurrences. Locate the equipment close to a drain that is capable of handling the maximum drain flow rate during backwash.

**Flexible Connectors -** Some tanks expand and contract over the acceptable range of operating water pressures of the Magnum control valve. The use of flexible connectors is recommended on polywound or fiberglass tank installations of 24-inch (60.96-cm) diameter and larger. Follow the tank manufacturer's instructions for more information.

**Inlet and Outlet Piping -** Inlet and outlet plumbing should be adequately supported to avoid excessive loads on the valve. Install a manual bypass system to provide for occasions when the water conditioner must be bypassed for servicing.

**Drain Line Piping -** To prevent mineral loss during backwash, and to ensure proper operation of the Magnum Cv Series control valve, **A DRAIN LINE FLOW CONTROL** must be plumbed into the drain line prior to placing the valve in the service mode. Flow controls from 5 to 40 gpm (18.92 to 151.4 Lpm) are available from GE Water Technologies and can be easily installed in the drain line. Flow controls greater than 40 gpm (151.4 Lpm) must be plumbed externally. Selection of the proper drain line flow control depends on the tank size and media used for the installation. See Section 20.2 and 20.3.

### Magnum Valve Installation Guide (Top Mount)

Before the installation of the internal distribution system and loading of the media into the tank, the Magnum valve must be temporarily installed onto the tank. This will ensure that correct alignment of the inlet and outlet piping once the internals are installed and the media is loaded onto the tank.

1. Install tank O-ring into the tank adapter section at the bottom of the Magnum valve. **Be sure to lightly lubricate the O-ring with the 100% silicone lubricant provided with the valve.** Lubricant is mainly used to hold O-ring in place during the valve installation.
2. Screw the Magnum valve onto the empty tank until O-ring touches the top of the tank.
3. Turn (tighten) the Magnum valve an additional 60° to 90° (max).
4. Align valve with plumbing connections to minimize unnecessary stress.
5. For reference, place a mark on the tank beneath the front center of the Magnum valve.
6. Remove the Magnum valve in preparation for installation of the internals and media loading.
7. Prior to loading media, make sure the tank alignment is correct using the mark on the front of the tank.
8. Cut riser 1/4-inch above the top of the tank, plus or minus 3/8 inch. Place riser inside the tank.
9. Load media following your supplier's recommendations.
10. Follow piping recommendations to provide support and flexibility. Layout piping to accommodate for FRP tanks and piping dimensional changes and potential water hammering. Flexible connectors may be needed.
11. Proper pipe alignment is needed.

Flex connectors are recommended when installing valves on FRP tanks that are 24 inches or larger in diameter.

The following general drain line piping guidelines should be observed:

- 1 inch (2.54 cm) or larger piping
- Should not exceed 20 feet (6.1 m)
- Should not be elevated higher than five feet above the control valve
- No shut-off valves should be installed in drain line
- Minimal number of elbows and fittings should be installed in drain line
- Piping must be self-supporting
- Flow control should be installed as close to the Magnum Cv Series control valve as possible if an external flow control is used.

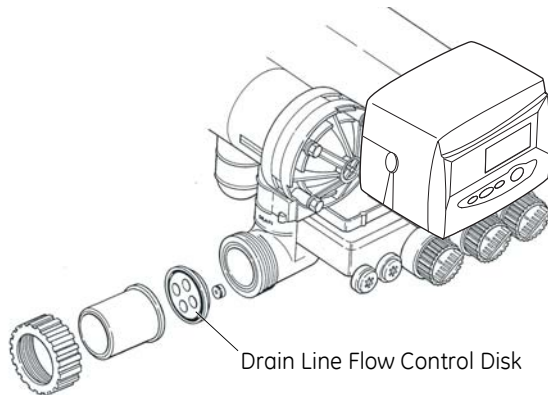

Figure 3.1

**Brining System** - The Magnum control valve utilizes timed water refill to add water to the salt tank. A refill tube with check ball is required in the brine tank that does not restrict the refill or brine draw flow rate capabilities of the valve. Although not required, a separate brine valve (safety float) system is recommended for use with Magnum installations. Select a "High-Flow" brine valve that does not restrict the refill or brine draw flow rate capabilities of the valve. The "Performance Injectors and Magnum Flow Controls" section (Sections 19.0 and 20.0) of this manual contains flow rate information for various size injectors and refill controllers.

**Pilot Drain** - During regeneration, a small amount of water (200 ml or 1 cup) is discharged from the 1/4-inch (6.3-mm) tube fitting on the back of the valve marked DRAIN (Figure 3.2). To prevent this water from being discharged to the floor, plumb this connection to a non-pressurized drain or to the brine tank. **Do not plug or apply back pressure to the pilot drain at any time.**

Crimping the pilot drain line or installing the line to go up, which causes backpressure, prevents the diaphragm cartridges from shifting properly through the cycles of regeneration or backwash.

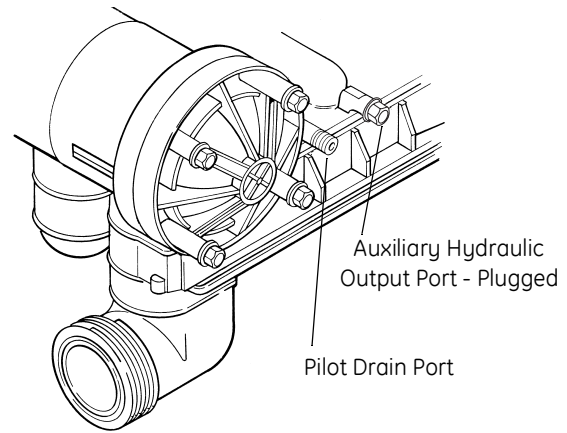

Figure 3.2

### Electrical

---

**CAUTION:** This valve and control are for dry location use only unless used with a Listed Class 2 power supply suitable for outdoor use.

---

1. Electrical requirements for the installation depends on the configuration of the control.
2. The standard North American Series Logix electronic control is supplied with a 12 volt wall mount transformer. Optional wall mount transformers are available in the following configurations: Japanese plug @ 100 volts/50 or 60 Hz, Australian/Argentine plug @ 240 volts/50 Hz, British plug @ 240 volts/50 Hz, European/Italian plug @ 230 volts/50 Hz. Optional transformers must be ordered separately for all international 12 VAC configurations.

### Lubricants

It is very important that 100% silicone lubricant is the only lubricant used for installing the Magnum control valve. Any other lubricant may cause material degradation and potential failure of the valve components.

**NOTE:** Some silicone based lubricants contain petroleum-based ingredients. If there is a question about the lubrication that you are using contact the lubricant manufacturer to be sure the product is 100% silicone.

### 3.1 Typical Installation Drawings

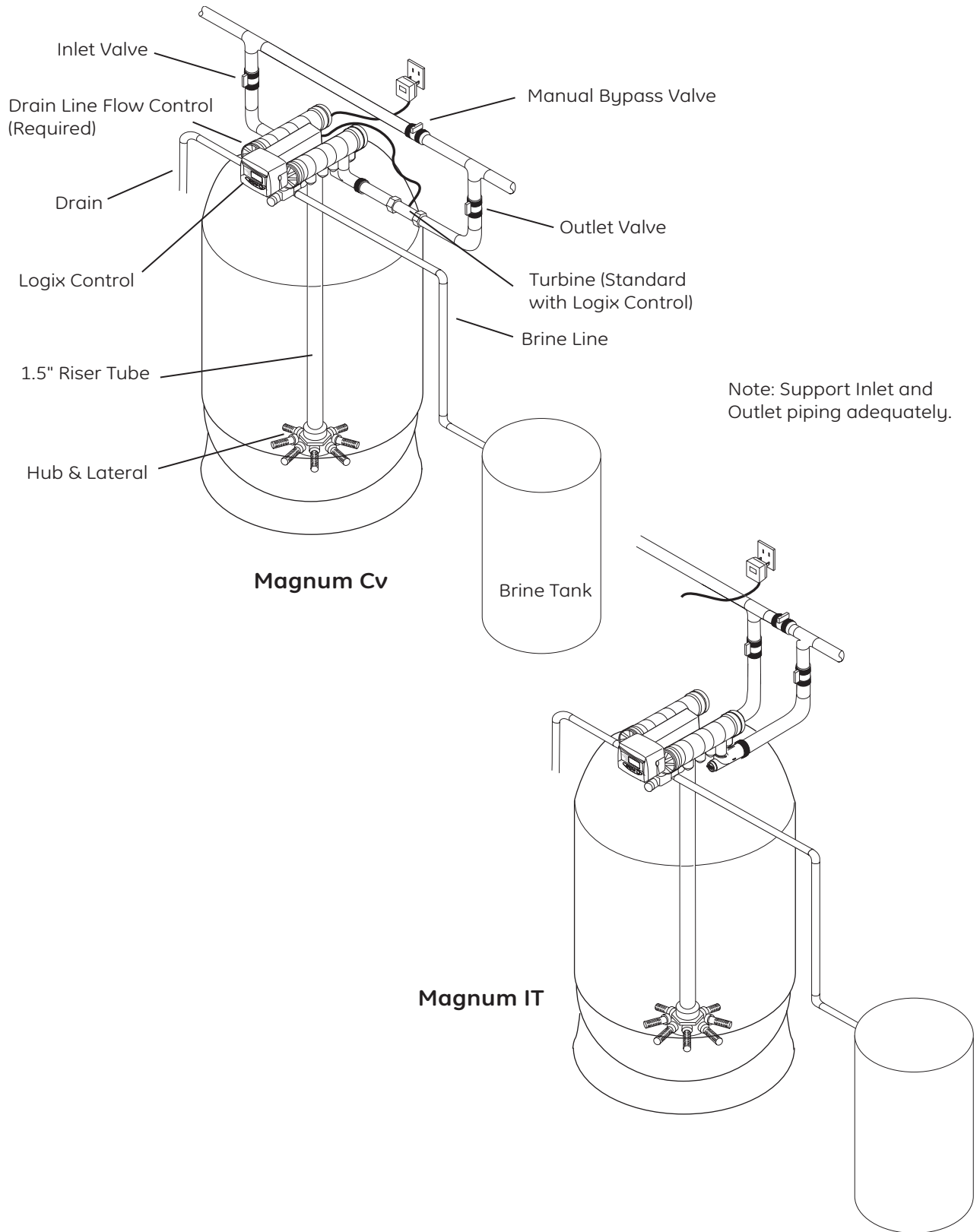

Figure 3.3 Magnum Cv and Magnum IT, Single Tank Softener Units with Logix Electronic Control

## 4.0 Flow Diagrams

The Magnum control valve utilizes a series of pilot valves to properly position the diaphragm valve cartridges (Figure 4.1). The pilot valves are activated by the camshaft (Figure 4.2). The flow diagrams that follow represent the **Service Cycle** for a 5-cycle conditioner and

3-cycle filter configuration. Both the Hardwater Bypass and No Hardwater Bypass service flow diagrams are presented.

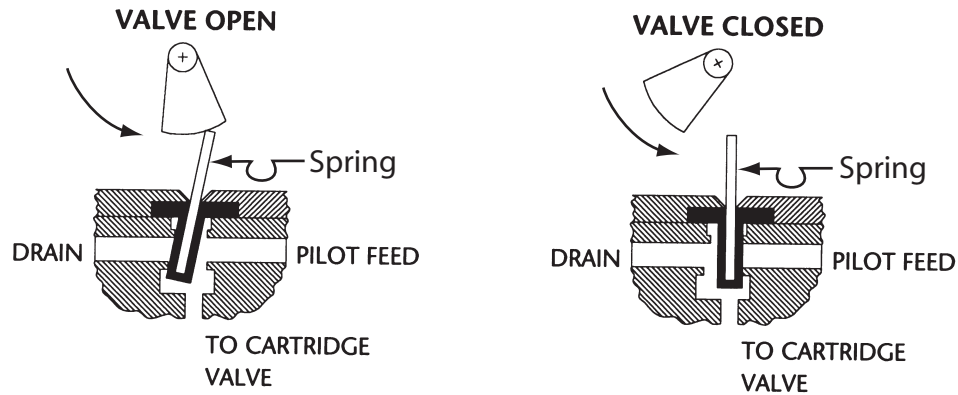

Figure 4.1 Pilot Valve Principle of Operation, Front View

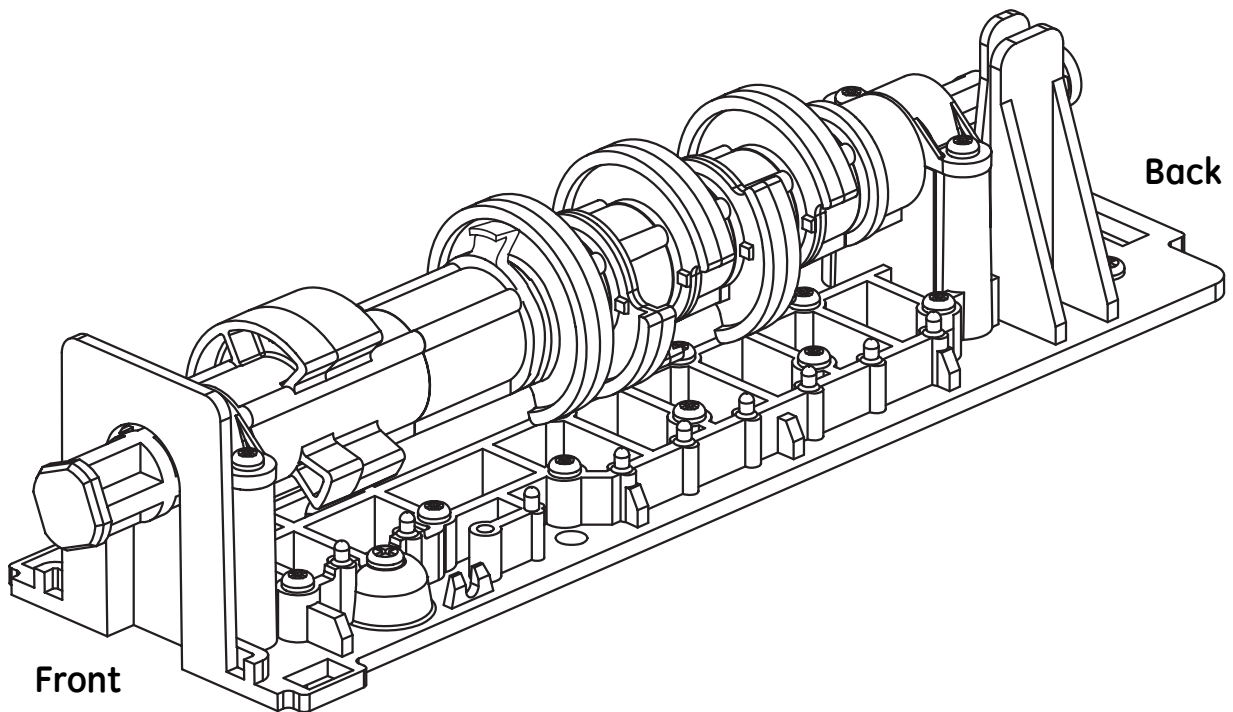

Figure 4.2 Cam Assembly

# Magnum 5-Cycle Conditioner Hard Water Bypass Service Cycle

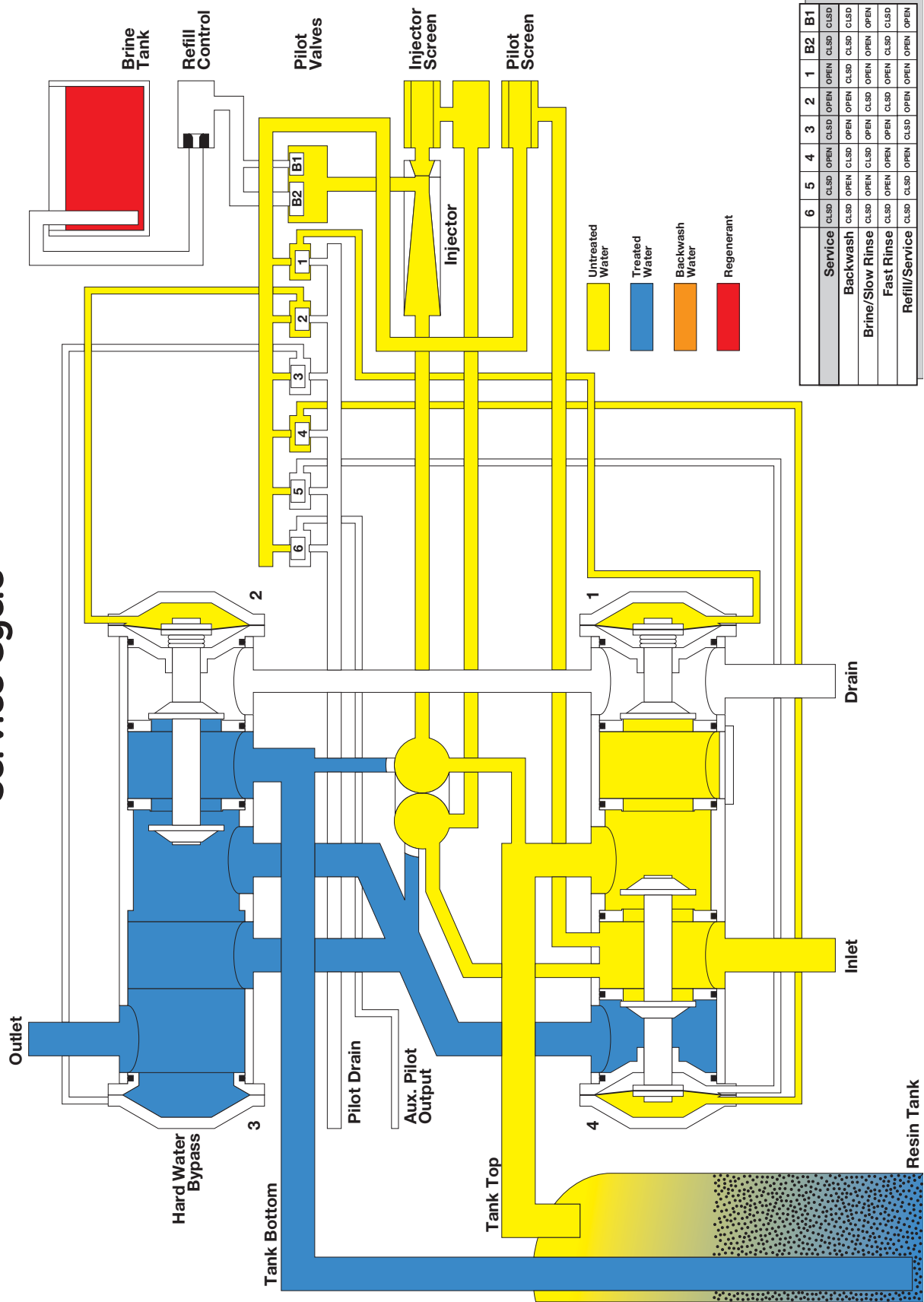

Figure 4.3

# Magnum 5-Cycle Conditioner No Hard Water Bypass Service Cycle

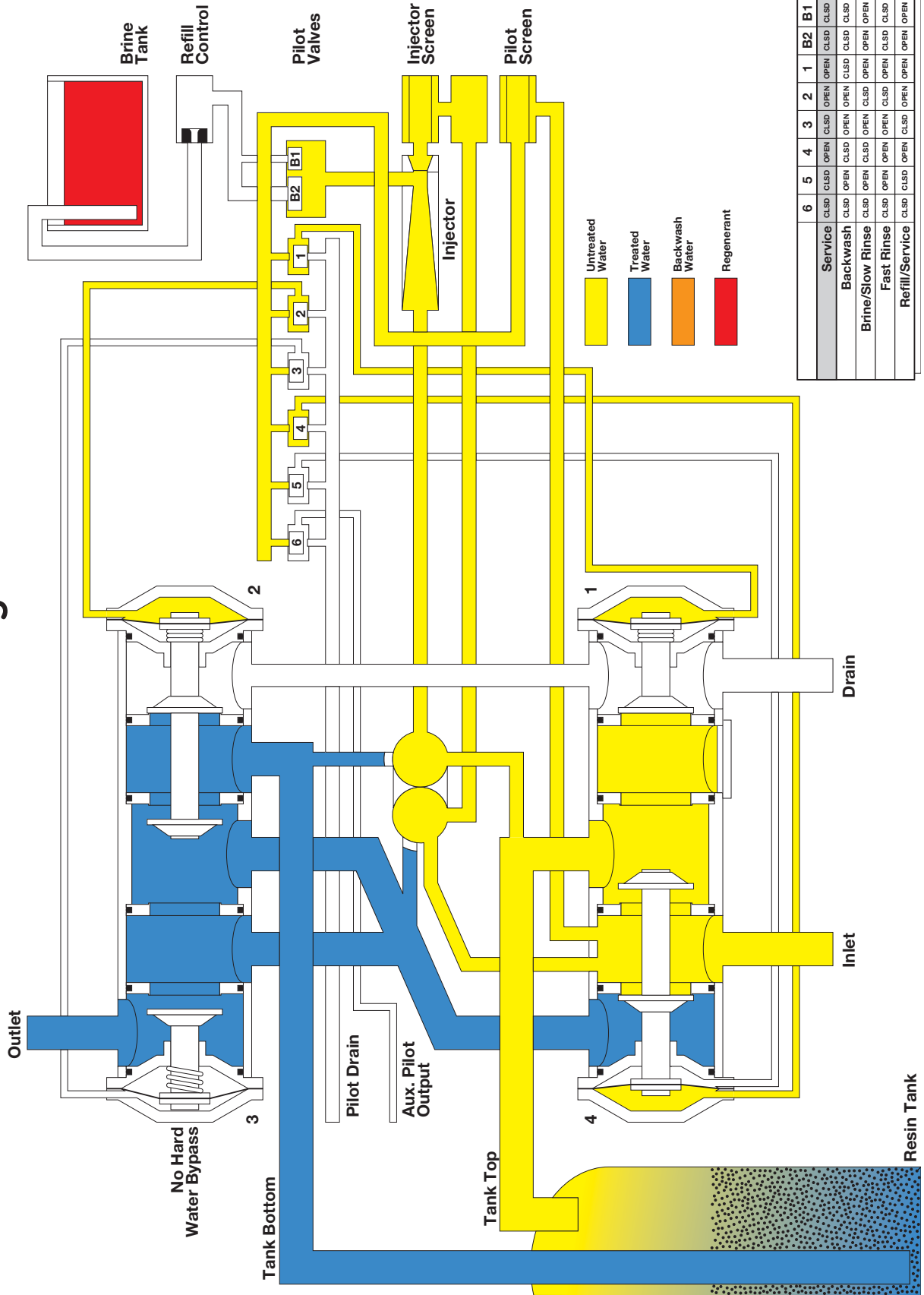

Figure 4.4

# Magnum 3-Cycle Filter: Unfiltered Water Bypass Service Cycle

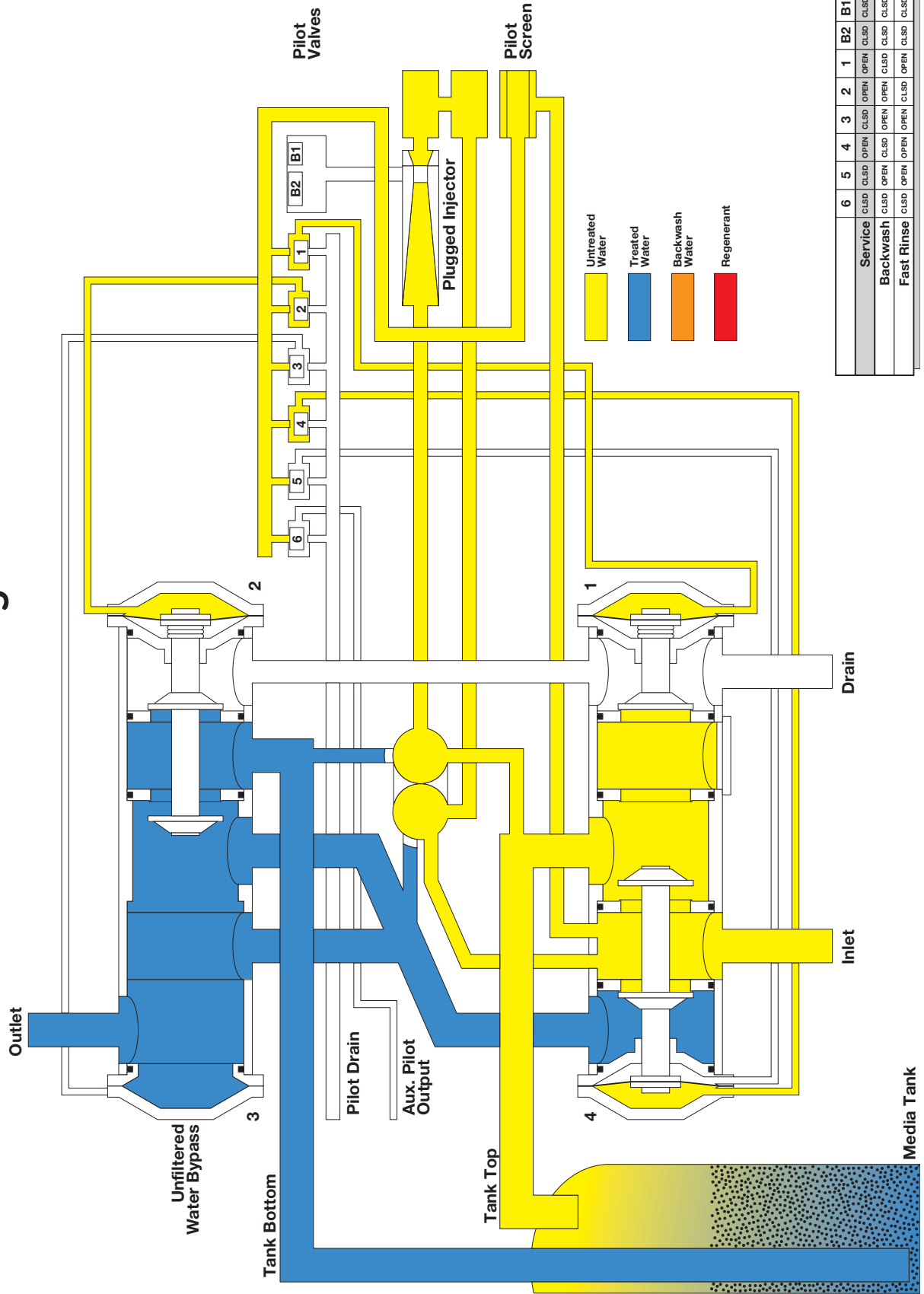

Figure 4.5



# Magnum 3-Cycle Filter: No Unfiltered Water Bypass Service Cycle

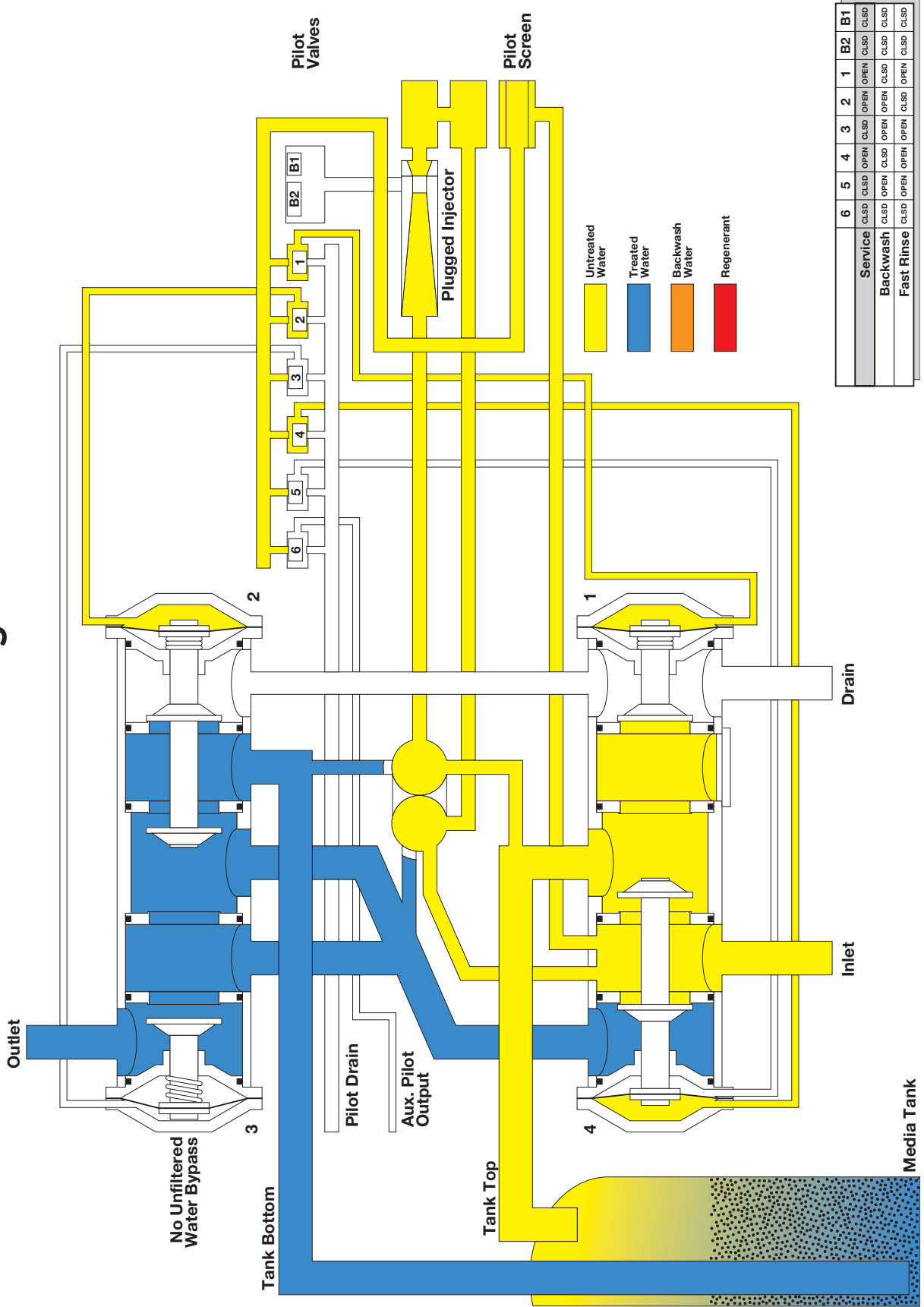

Figure 4.6



## 5.0 Identifying the Logix Control: 742/742F Time Clock or 762/762F Demand and Magnum Valve

If you are unsure of your control model, simply remove the cover and disconnect the controller module from the control valve. In the back of the control valve is a silver label that shows your model number and version revision.

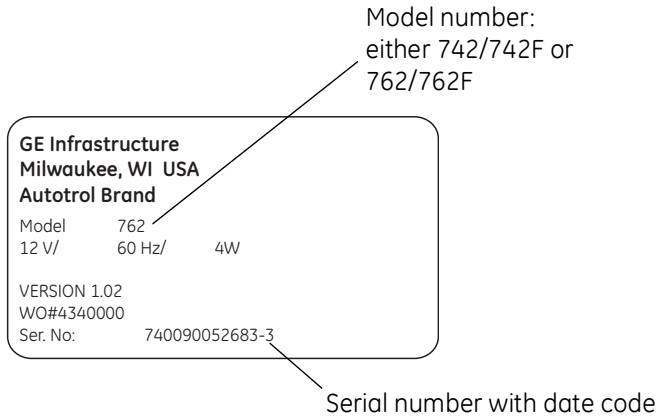

Figure 5.1

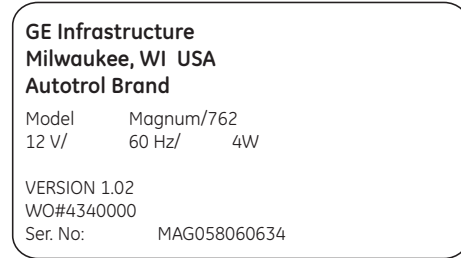

Figure 5.2

### How To Read the Serial Number



Figure 5.3

## 6.0 General Logix Series Instructions

### 6.1 Display Icons Logix Controller

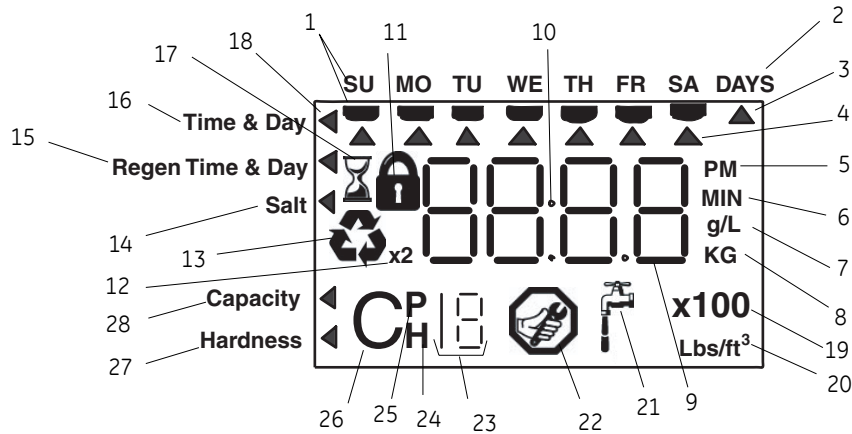

Figure 6.1

**NOTE:** In normal operation and during programming, only a few of the icons are actually displayed.

1. Days of the week. The flag immediately below the day appears when that day has been programmed as a day the system should regenerate (used with 7-day timer programming).
2. See #3
3. This cursor is displayed when the days between regeneration are being programmed (used with .5 to 99 day regeneration programming).
4. One of these cursors is displayed to indicate which day will be programmed into the controller.
5. "PM" indicates that the time displayed is between 12:00 noon and 12:00 midnight (there is no AM indicator). PM indicator is not used if clock mode is set to 24-hour.
6. When "MIN" is displayed, the value entered is in minute increments.
7. When g/L is displayed, the value for regenerant amount entered is in grams/Liter.
8. When "Kg" is displayed, the value entered is in kilograms or kilograins.
9. Four digits used to display the time or program value. Also used for error codes.
10. Colon flashes as part of the time display. Indicates normal operation (742 only).
11. Locked/unlocked indicator. In Level I programming this is displayed when the current parameter is locked-out. It is also used in Level II programming to indicate if the displayed parameter is locked (icon flashes) when controller is in Level I.
12. When "x2" is displayed, a second regeneration has been called for.
13. The recycle sign is displayed (flashing) when a regeneration at the next time of regeneration has been called for. Also displayed (continuous) when in regeneration.
14. The display cursor is next to "SALT" when programming the amount of regenerant. If the controller is on a 3-cycle filter then backwash time is programmed.
15. The display cursor is next to "REGEN TIME & DAY" when programming the time of regeneration and the days of regeneration.
16. The display cursor is next to "TIME & DAY" when programming the current time and day.
17. The hourglass is displayed when the motor is running. The camshaft should be turning.
18. These cursors appear next to the item that is currently displayed.
19. X100 multiplier for large values.

20. When Lbs/ft<sup>3</sup> is displayed the value for regenerant amount entered is in pounds/cubic foot.
21. Faucet is displayed when the current flow rate is displayed. Control may show the faucet and "0", indicating no flow.
22. Maintenance interval display turns on if the months in service exceed the value programmed in P11.
23. Used with #24, #25, and #26. Displays a sequence number or a value.
24. History Values (H). The number displayed by #23 identifies which history value is currently displayed.
25. Parameter (P). Displayed only in Level II Programming. The number displayed by #23 identifies which parameter is currently displayed.
26. Cycle (C). The number displayed by #23 is the current cycle in the regeneration sequence.
27. Hardness setting—only used with 760 and 762 controllers.
28. Capacity display—shows estimated system capacity.

## 6.2 Keypad — Buttons

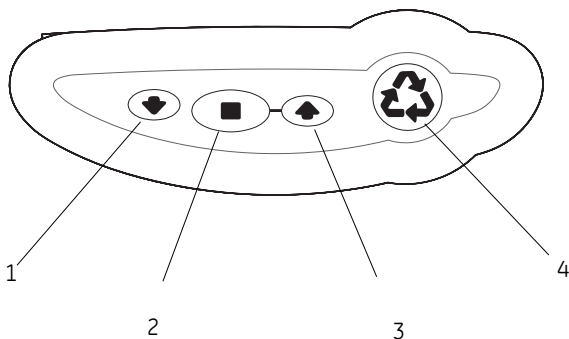

Figure 6.2

1. DOWN arrow. Generally used to scroll down or increment through a group of choices.
2. SET. Used to accept a setting that normally becomes stored in memory. Also used together with the arrow buttons.
3. UP arrow. Generally used to scroll up or increment through a group of choices.
4. Regenerate. Used to command the controller to regenerate. Also used to change the lock mode.

**NOTE:** If a button is not pushed for thirty seconds, the controller returns to normal operation mode. Pushing the Regenerate button immediately returns the controller to normal operation.





## 6.3 Programming Conventions

The 700 series controller is programmed using the buttons on the keypad. The programming instructions are described two ways whenever a section has keypad input.

First, a table shows simplified instructions. Second, text follows that describes the action. In each table:

"Action" lists the event or action desired.

"Keys" are listed as:

-  UP for up arrow
-  DOWN for down arrow
-  SET for set
-  REGEN for regeneration

"Duration" describes how long a button is held down:

P/R for press and release

HOLD for press and hold

X sec for a number of seconds to press the button and hold it down

"Display" calls out the display icons that are visible.

---

---

## 7.0 742/762 Series Initial Power-Up

### Initial Power Up

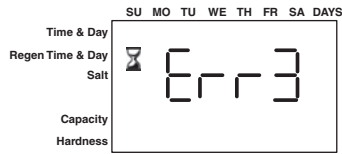

Before mounting the controller check the position of the camshaft. The correct rotation position is when the arrows on the camshaft and the arrows on the pillow block line up (see Figure 2.3).

If the arrows do not line up, rotate the camshaft by hand counterclockwise. Once the arrows line up, pull the camshaft back (see Figure 2.4).

Mount the Control

1. Mount the controller on the valve. Do not engage the camshaft.
2. Apply power to the controller. The display will show an hour glass and Err3. This is an indication that the controller is moving to the treated water (HOME position). Err3 will change and the hour glass will disappear when the cycle is complete.

**NOTE:** If more than two minutes elapses, verify that the motor is turning the camshaft socket. If it is not turning, contact your dealer.

3. Engage the camshaft with the controller.

**NOTE:** The 700 Series controller features a self-test sequence. At first power-up of the control, you may see a number such as 1.00, 1.02, 1.04, or 2.00 displayed. This is an indication that the self-test is not completed. To complete the test, verify that the turbine cable is connected. Blow air into the turbine port (valve outlet) to spin the turbine. The controller verifies that the turbine works and the self-test finishes. Proceed with the initial start-up procedure.

---

---

## 8.0 Initial Programming Instructions

### 8.1 Start-Up Programming

The Logix Magnum control can be quickly programmed by following the sequential procedures on the following pages. Additional customization information is in Section 13.0 *742/762 Level II Programming*. Listed below is general information about the programming features.

#### Valve Type

Your system's OEM may have performed this setting. If so proceed to the next step.

- This setting is used to calibrate the Logix program to the actual valve type. Identification stickers on the Logix control and the valve body show the control and valve type. See Section 5.0 *Identifying the Logix Control* for more information.
- Valve models displayed by the Logix control

255	255, 7-cycle conditioner
263	Performa, 3- cycle filter
268	Performa, 5-cycle conditioner
273	Performa Cv, 3-cycle filter
278	Performa Cv, 5-cycle conditioner
293	Magnum, 3-cycle filter
298	Magnum, 5-cycle conditioner

#### Program System Size

Your system's OEM manufacturer may have performed this setting. If so, proceed to setting the Time of Day. The system size setting represents the amount of media in the tank.

#### Time of Day

The Time of Day is preset in the factory at 1200 pm operating as a 12-hour clock. This setting can be changed to operate as a 24-hour clock. See Section 13.0 *Level II Programming*.

#### Day of the Week

Program this setting to the actual day of the week. The Logix control is then properly calibrated to allow accurate recovery of average daily water usages for each day of the week. See Section 15.0 *Accessing History Values* for more information.

#### Time of Regeneration or Backwash

A fully adjustable clock setting allows regenerations or backwashes to be programmed at any time of the day. Also used to offset regenerations or backwashes when two systems are plumbed in series.

#### Days Override

Can be used as a backup for 762 Demand systems. Represents the days between regeneration. Also can be programmed as a 7-Day clock on 742 Time clock controls (see Section 9.0).

#### Regenerant Dosage (762/742 5-Cycle Conditioners) or Backwash Time (762F/742F 3-Cycle Filters)

- 762/742 Conditioners: Represents salt dosage per cubic foot of media. See Table 8.1 for salt dosages and capabilities.
- 762F/742F Filters: Represents the backwash cycle time in minutes. This is fully adjustable.





#### Capacity

Calculated by the Logix software, using the resin volume, regenerant dosage, and hardness settings. Can be overridden for 762 5-cycle conditioners. "View Only " for 742 5-cycle conditioners. See Section 13.0 I to program as metric equivalent.

#### Hardness

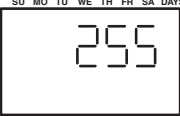
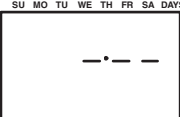
Program actual water hardness of feed water. See Section 13.0 *Level II Programming* to program as metric equivalent.

# Logix Magnum Time Clock 742/298 - 5-Cycle Conditioner

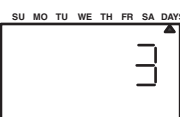
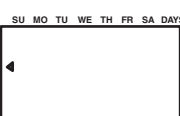
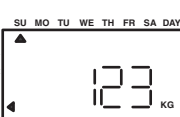
Screen	Buttons to Press	Description	Range
 <p>Time &amp; Day Regen Time &amp; Day Salt Amount Capacity Hardness</p>	<p>then ↓ or ↑ press ■</p>	1. Valve Type — Select 298	
 <p>Time &amp; Day Regen Time &amp; Day Salt Amount Capacity Hardness</p>	<p>then ↓ or ↑ press ■</p>	2. Resin Volume — Select correct resin volume	Cubic feet: 3.00 to 20.00
 <p>Time &amp; Day Regen Time &amp; Day Salt Amount Capacity Hardness</p>	<p>press ■ then ↓ or ↑ press ■</p>	3. Time of Day (12 hr.) — Set to time of day Note: Setting includes PM indicator.	
 <p>Time &amp; Day Regen Time &amp; Day Salt Amount Capacity Hardness</p>	<p>press ■ then ↓ or ↑ press ■</p>	4. Day of Week — Set to actual day of the week	
 <p>Time &amp; Day Regen Time &amp; Day Salt Amount Capacity Hardness</p>	<p>press ■ then ↓ or ↑ press ■</p>	5. Time of Regeneration — Set to desired time of regeneration	
 <p>Time &amp; Day Regen Time &amp; Day Salt Amount Capacity Hardness</p>	<p>press ■ then ↓ or ↑ press ■</p>	6. Days Between Regeneration — Set to desired days between regeneration or — *Set at 0 to program as a 7-day timer	Days: .5 to 99
 <p>Time &amp; Day Regen Time &amp; Day Salt Amount Capacity Hardness</p>	<p>press ■ then ↓ or ↑ press ■</p>	7. Salt Dosage — Set to desired desired dosage lbs per cubic feet of resin	Lbs/ft <sup>3</sup> : 3 to 18
 <p>Time &amp; Day Regen Time &amp; Day Salt Amount Capacity Hardness</p>	<p>press ↓</p>	8. Estimated Capacity (view only) — Based on resin volume and salt setting	

Programming is complete

**Service Display**

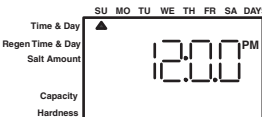

Displays actual day of the week and time of day

\* See Section 8.2 for details.



# Logix Magnum Demand 762/298 - 5-Cycle Conditioner





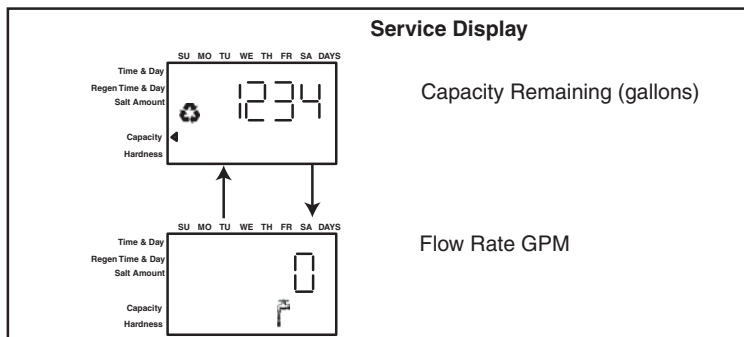

Screen	Buttons to Press	Description	Range
<p>Time &amp; Day Regen Time &amp; Day Salt Amount Capacity Hardness</p>	<p>then ↓ or ↑ press ■</p>	1. Valve Type — Select 298	
<p>Time &amp; Day Regen Time &amp; Day Salt Amount Capacity Hardness</p>	<p>then ↓ or ↑ press ■</p>	2. Resin Volume — Select correct resin volume	Cubic feet: 3.00 to 20.00
<p>Time &amp; Day Regen Time &amp; Day Salt Amount Capacity Hardness</p>	<p>press ■ then ↓ or ↑ press ■</p>	3. Time of Day (12 hr.) — Set to time of day Note: Setting includes PM indicator.	
<p>Time &amp; Day Regen Time &amp; Day Salt Amount Capacity Hardness</p>	<p>press ■ then ↓ or ↑ press ■</p>	4. Day of Week — Set to actual day of the week	
<p>Time &amp; Day Regen Time &amp; Day Salt Amount Capacity Hardness</p>	<p>press ■ then ↓ or ↑ press ■</p>	5. Time of Regeneration — Set to desired time of regeneration	
<p>Time &amp; Day Regen Time &amp; Day Salt Amount Capacity Hardness</p>	<p>press ■ then ↓ or ↑ press ■</p>	6. Days Override — Leave at 0 to disable or — Set to desired days override	Days: .5 to 99
<p>Time &amp; Day Regen Time &amp; Day Salt Amount Capacity Hardness</p>	<p>press ■ then ↓ or ↑ press ■</p>	7. Salt Dosage — Set to desired dosage lbs per cubic feet of resin	Lbs/ft <sup>3</sup> : 3 to 18
<p>Time &amp; Day Regen Time &amp; Day Salt Amount Capacity Hardness</p>	<p>press ↓ to override press ■ then ↓ or ↑ press ■</p>	8. Capacity — Capacity calculated by Logix control — Use to OVERRIDE calculated capacity	Kilograms: 1 to 900
<p>Time &amp; Day Regen Time &amp; Day Salt Amount Capacity Hardness</p>	<p>press ■ then ↓ or ↑ press ■</p>	9. Hardness — Set to actual water hardness in grains per gallon	Grains/gal: 3 to 200

Programming is complete

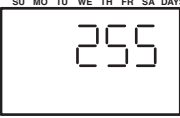
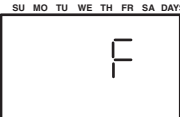

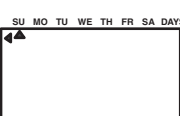
Toggles back and forth  
between displays when in  
the service position

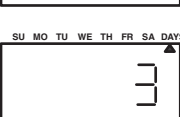
# Logix Magnum Time Clock 742F/293 - 3-Cycle Filter

Screen	Buttons to Press	Description	Range
Time & Day Backwash Time & Day Backwash Length Capacity	 then ↓ or ↑ press ■	1. Valve Type — Select 293	
Time & Day Backwash Time & Day Backwash Length Capacity	 press ■	2. Program Type — Select "F"	
Time & Day Backwash Time & Day Backwash Length Capacity	 press ■ then ↓ or ↑ press ■	3. Time of Day (12 hr.) — Set to time of day Note: Setting includes PM indicator.	
Time & Day Backwash Time & Day Backwash Length Capacity	 press ■ then ↓ or ↑ press ■	4. Day of Week — Set to actual day of the week	
Time & Day Backwash Time & Day Backwash Length Capacity	 press ■ then ↓ or ↑ press ■	5. Time of Backwash (12 hr) — Set to desired time of backwash	
Time & Day Backwash Time & Day Backwash Length Capacity	 press ■ then ↓ or ↑ press ■	6. Days Between Regeneration — Set to desired days between regeneration or — *Set to 0 to program as a 7-day timer	Days: .5 to 99
Time & Day Backwash Time & Day Backwash Length Capacity	 press ■ then ↓ or ↑ press ■	7. Backwash Length (minutes) — Set to desired backwash length	Minutes: 1 to 200

**Programmng is complete**

**Service Display**

Time & Day

Regen Time & Day

Salt Amount

Capacity

Hardness

SU MO TU WE TH FR SA DAYS



Displays actual day of week and time of day.

\* See Section 8.2 for details.

# Logix Magnum Demand 762F/293 - 3-Cycle Filter

Screen	Buttons to Press	Description	Range
	then ↓ or ↑ press ■	1. Valve Type — Select 293	
	press ■	2. Program Type — Select "F"	
	press ■ then ↓ or ↑ press ■	3. Time of Day (12 hr.) — Set to time of day Note: Setting includes PM indicator.	
	press ■ then ↓ or ↑ press ■	4. Day of Week — Set to actual day of the week	
	press ■ then ↓ or ↑ press ■	5. Time of Backwash — Set to desired time of backwash	
	press ■ then ↓ or ↑ press ■	6. Days Override — Leave at 0 to disable or — Set to desired days override	Days: .5 to 99
	press ■ then ↓ or ↑ press ■	7. Backwash Length (minutes) — Set to desired backwash length	Minutes: 1 to 200
	press ■ then ↓ or ↑ press ■	8. Capacity (gallons) — Set to desired capacity in gallons multiples of 100	Gallons: 1 to 900 x 100

## Programming is complete

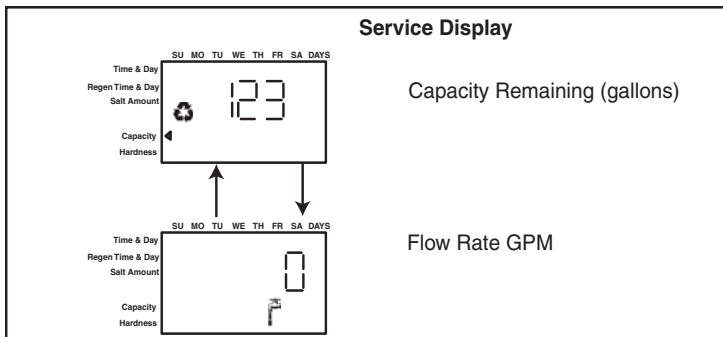

Toggles back and forth between displays when in the service position

## 8.2 Exchange Capacities, Setting 7-Day Clock, Viewing Cycle Times

**Table 8.1 Standard Efficiency Exchange Capacity**

Salt lbs/cu ft	Exchange Capacity grains/cu ft	Salt grams/liter	Exchange Capacity grams/liter
3	12714	50	29.9
4	15495	60	34.0
5	17774	70	37.5
6	19661	80	40.6
7	21250	90	43.4
8	22618	100	45.9
9	23828	110	48.2
10	24930	120	50.2
11	25962	130	52.1
12	26950	140	53.8
13	27916	150	55.5
14	28873	170	58.5
15	29829	200	62.7
16	30796	230	66.9
17	31783	260	71.0
18	32806	290	75.3

### Setting the 7-Day Clock (742 and 742F)

- Set the Days Override to "0".
- Press SET to advance the display to the Backwash Time/Day setting.
- Press SET. A flashing cursor appears beneath the "SU" display.
- Press UP or DOWN while the cursor is flashing to program a regeneration for that day. A black bar appears below the day.

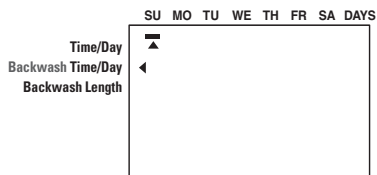

**NOTE:** Pressing SET again removes the black bar and deselects the day of regeneration.

- Press SET. This returns the flashing cursor to a solid cursor.
- Press UP or DOWN to navigate to other days of the week.

- Repeat the procedure to program regeneration on desired days. The days selected for regeneration are shown when the Logix control returns to the service display.

### Viewing Cycle Times

1. Press and hold the UP and SET buttons for 3 seconds when the control is in the "in service mode" to access the "cycle time display mode". The display shows a small "c" followed by a number in the lower portion of the display.
2. Press the UP and DOWN buttons to display the programmed cycle time.
3. Press the REGEN button to exit the "cycle times display mode".

**NOTE:** For adjusting cycle times, see *Section 14.0 Adjusting Cycle Times*.

**NOTE:** The draw and refill cycle times cannot be changed in cycle time programming for conditioner valves. Draw and refill times are calculated using the draw and refill rates and salt amounts. The draw and refill cycle times may be programmed for 3-cycle filters.

## 9.0 Regeneration Modes

The 700 Series controllers can be regenerated either automatically or manually. During a regeneration, the total time remaining of the regeneration is displayed on the controller. The current cycle is shown in the lower left of the display.

### Manual Regeneration:

**Delayed Manual Regeneration** — Pressing the REGENERATION key programs a delayed manual regeneration. The regeneration icon on the LCD flashes indicating that a regeneration starts when the time of day reaches the programmed time of regeneration. Pressing the REGENERATION key again turns off the regeneration icon and cancels the delayed regeneration.

**Immediate Manual Regeneration** — Pressing and holding the REGENERATION key for three seconds initiates an immediate manual regeneration. The regeneration icon on the LCD turns on. The control goes to the regenerating mode.

**Delayed Second Regeneration** — Pressing the REGENERATION key while the control is in the regenerating mode programs a delayed second regeneration. The x2 icon next to the regeneration icon flashes indicating a second regeneration starts when the time of day reaches the programmed time of regeneration.

**Double Immediate Manual Regeneration** — Pressing and holding the REGENERATION key for three seconds while the control is in the regenerating mode programs back-to-back manual regenerations. The x2 icon next to the regeneration icon turns on indicating a second manual regeneration starts immediately after the current regeneration is complete.

### During a Regeneration:

- A "C#" is displayed to show current cycle.

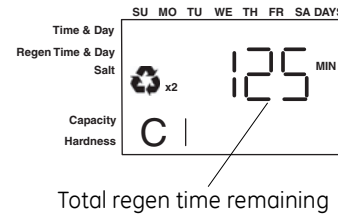

- Total regen time remaining is displayed on screen.
- Press and hold SET to show current cycle time remaining.

### To Advance Regeneration Cycles:

- Press and hold SET - showing current cycle time.
- Simultaneously press SET and UP to advance on cycle. An hourglass displays while the cam is advancing. When the cam reaches next cycle, "C2" is displayed.
- Repeat SET and UP to advance through each cycle.
- Press and hold SET and UP for 5 seconds to cancel regen. Hourglass flashes once cancelled. Camshaft advances to home - may take 1 to 2 minutes.

### Regeneration Cycles:

- C1 – Backwash
- C2 – Regeneration Draw/Slow Rinse (not used in filter mode)
- C3 – Slow Rinse (not used in filter mode)
- C5 – Fast Rinse cycle C8 – Regenerant Refill (not used in filter mode)

## 10.0 Placing Conditioner into Operation (turning on the water)

### Conditioner and 5-Cycle Filter Start-Up

After you have performed the previous initial power-up steps, you need to place the conditioner into operation. Follow these steps carefully, as they differ from previous Autotrol valve instructions.



**WARNING:** Do not rotate the camshaft by hand or damage to the unit may occur. Use the controller to step the camshaft electronically through the cycles.

1. Remove the cover from the valve. Removing the cover allows you to see that the camshaft is turning, and in which cycle the camshaft is currently positioned.
2. With the supply water for the system still turned off, position the bypass valve to the “not in bypass” (normal operation) position.
3. Hold the REGEN button on the controller down for 5 seconds. This initiates a manual regeneration.

The controller indicates that the motor is turning the camshaft to the cycle C1 (Backwash) position by flashing an hourglass. The controller displays the total regen time remaining.

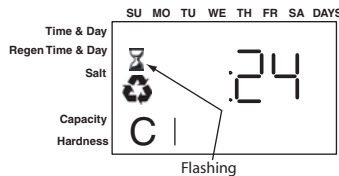

If you press and hold the SET button, the controller indicates the time remaining in the current cycle.

4. Fill the media tank with water.
  - A. While the controller is in cycle C1 (Backwash), open the water supply valve very slowly to approximately the 1/4 open position.



**WARNING:** If opened too rapidly or too far, media may be lost out of the tank into the valve or the plumbing. In the 1/4 open position, you should hear air slowly escaping from the valve drain line.

- B. When all of the air has been purged from the media tank (water begins to flow steadily from the drain line), open the main supply valve all of the way. This purges the final air from the tank.

- C. Allow water to run to drain until the water runs clear from the drain line. This purges any refuse from the media bed.
- D. Turn off the water supply and let the system stand for about five minutes. This allows any air trapped to escape from the tank.

5. Add water to the regenerant tank (initial fill)
  - A. Add enough water to the regenerant tank to ensure a proper regeneration. Refer to the programmed salt dosage.

If the tank has a salt platform in the bottom of the tank, add water until the water level is approximately 1 inch (25 mm) above the platform.

**NOTE:** We recommend that you do not put regenerant into the tank until after the control valve has been put into operation. With no regenerant in the tank, it is much easier to view water flow and motion in the tank.

6. Engage the refill cycle to prime the line between the regenerant tank and the valve (conditioner only).
  - A. Slowly open the main water supply valve again, to the fully open position. Be sure not to open too rapidly as that would push the media out of the media tank.
  - B. Advance the controller to the Refill (C8) position. From cycle C1 (Backwash), press and hold the SET button. This displays the current cycle.

While pressing the SET button, press UP to advance to the next cycle. Continue to advance through each cycle until you have reached cycle C8 (Refill).

- C. With the water supply completely open, when you arrive at cycle C8 (Refill), the controller directs water down through the line to the regenerant tank. Let the water flow through the line until all air bubbles have been purged from the line.

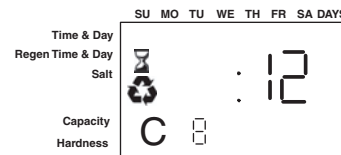

- D. Do not let the water flow down the line to the tank for more than one to two minutes, or the tank may overflow.

- 
- E. Once the air is purged from the line, press the SET button and the UP button simultaneously to advance to cycle C0 (Treated Water) position.
7. Draw water from the regenerant tank.
    - A. From the treated water position (cycle C0), advance the valve to the draw regenerant position. Hold the REGEN button down for five seconds.

The controller begins a manual regen, and advances the control valve to the cycle C1 (Backwash). Press the SET and UP button to advance to cycle C2 (Draw).

- B. With the controller in this position, check to see that the water in the regenerant tank is being drawn out of the tank. The water level in the tank should recede very slowly.
    - C. Observe the water being drawn from the regenerant tank for at least three minutes. If the water level does not recede, or goes up, check all hose connections. C2 should be displayed.
8. If the water level is receding from the regenerant tank you can then advance the controller back to the treated water (C0) position by pressing SET and the UP buttons simultaneously to advance the controller to the C0 position.
9. Finally, turn on a faucet plumbed after the water conditioner. Run the faucet until the water runs clear.

## 11.0 Programming the Logix for Manganese Greensand Systems

For other regenerants, after doing the steps in Section 8.2, proceed to *Special Applications*.

### Manganese Greensand Systems

#### Sizing 5-Cycle Filters

Potassium permanganate regenerating iron filters should be sized for the appropriate backwash and injector sizes.

#### Backwash Controller

Be sure to choose the appropriate backwash flow rate control (see *Parts* section) as recommended by your media manufacturer.

#### Injector

Use the same injector size as you would for your conditioner control tank diameter.

#### Refill Controller

An FA filter can use the refill control that is featured as standard with a Logix controller. Use a float valve in your potassium permanganate feeder to set potassium permanganate dosage.

#### Initial Resin Volume Setting

Programming for a manganese greensand system requires a few minor adjustments to the programming to operate the control correctly. The initial resin volume should be set to the closest volume of the manganese greensand in the system. For example, if the system contains two cubic feet of manganese greensand, program in 2.00 for the resin volume.

#### "Salt" Setting for $KMNO_4$ Regenerant

Be sure to set the salt dosage high enough to operate the float shut-off in the regenerant storage tank.

All other settings remain the same as mentioned in the previous programming sections.

#### Days Between Regeneration Setting (742)

To set the days between regenerations, consult the media manufacturer for the actual capacity of the media.

In general, manganese greensand has a capacity of 10,000 ppm of removal capability per cubic foot of media. Calculate the capacity of the system by taking the number of cubic feet of media and multiply by 10,000.

For example, using a 1 cubic foot system provides 10,000 ppm of removal capability.

The next step is to calculate the demand for the system. Multiply the predicted daily water usage by the iron content in ppm.

For example, an average person uses 75 gallons of water per day. Four people living in a home use 300 gallons of

water (75 gallons x 4 people) per day. Assume the incoming water has 10 ppm of iron. Now calculate the daily demand: multiply the gallons of water used per day (300) by the ppm of iron content (10) = 3000 ppm of daily capacity usage.

Now take the system capacity (10,000), divided by the daily demand (3,000) = 3.3 days of capacity. Since you run out of capacity before the beginning of the fourth day, the proper setting for days between regeneration is 3 days.

For example:

4 people x 75 gals per person = 300 gallons used per day.

10 ppm iron x 300 gal/day = 3000 ppm/day

10,000 ppm capacity ÷ 3000 ppm/day = 3.3 days of total capacity

Solution = regenerate every 3 days.

The above capacity numbers are based only on Fe. For removal of  $H_2S$  and Mn refer to the media manufacturers specifications.

#### Volume/Demand Regeneration Setting

To set a 762 demand system for iron removal you must:

1. Know your media capacity. Generally, one cubic foot of magnesium greensand can remove 10,000 ppm of iron.
2. Know the iron concentration in your water.

To have your system regenerate on demand, set your system's capacity (P7) to the appropriate factor. On the 762, it reads Kg, but you are actually working in ppm of iron.

1. If your system is one cubic foot, set the capacity to "10" kg, meaning 10,000. For two cubic feet, set the capacity to "20" kg.

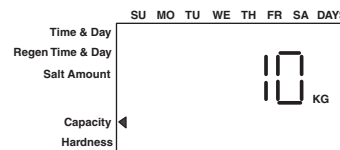

2. Set your hardness to the level of ppm iron in your water. If you have 3 ppm of iron, set the 762 control to "3".

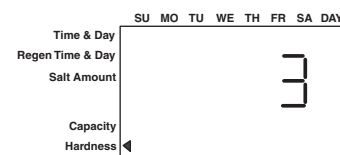

3. The control calculates the remaining volume capacity in gallons ( $m^3$ ) and counts down to regeneration.



---

## 11.1 Special Applications – How to Program the 742/762

For all special flow applications that are media or regenerant dependent, you are going to select the injector, the backwash flow control and the refill flow control.

You may need to change one or all the regenerating cycle times to satisfy your equipment needs.

The Logix control must be programmed as a 3-cycle filter to allow all cycles to be adjustable. See pages 27 or 28 to program the Logix Magnum as a 3-cycle filter. Proceed to the procedure listed below after completing filter programming.

### To Program The Times For All Cycles

- Press ↑ and ■ when in the "Service Mode" to enter the Cycle Time Display mode. The display will show "C1".
- Press ■ when in the "Cycle Time Display" mode. The cycle time in minutes will flash, indicating the cycle time can be changed.
- Press ↓ or ↑ to change the flashing time.
- Press ■ to enter the selected time.
- Press ↑ to navigate to another cycle.

---

## 12.0 Things You Might Need to Know

- When the controller is first plugged in, it may display a flashing hourglass and the message Err 3, this means that the controller is rotating to the home position. If the Err 2 is displayed, check that the incoming power frequency matches the controller. The North American controller does not run with 50 Hz input.
- The preset default time of regeneration is 2:00 AM.
- English or Metric? The World controller senses the electrical input and decides which is needed. The North American controller only runs on 60 Hz and defaults to English units.
- The Logix Series controller can be programmed to regenerate on specific days of the week.
- If electrical power is not available, the camshaft can be rotated counterclockwise by hand if the motor is removed.
- The Logix Series controllers send commands to the motor for camshaft movement. However, water pressure/flow are required during the regeneration cycle for backwash, purge and refill, and brine draw to actually take place.
- Make sure control power source is plugged in. The transformer should be connected to a non-switched power source.
- You can start programming at the beginning by resetting the amount of media. When viewing H0 (History Value) push and hold SET for five seconds. The display reverts back to --- and any programmed information is lost. Return to *Logix Series Initial Power Up*.

## 13.0 742/762 Level II Programming

The Logix Series controllers are designed to operate by only setting the time of day and the day of the week. The remaining settings have been set at the factory. These default settings work for most applications.

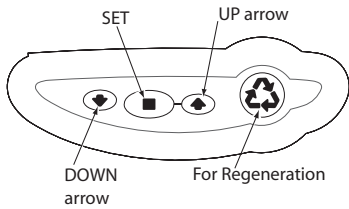

To enter Level II programming press and hold UP and DOWN for 5 seconds. A "P" value is displayed indicating Level II.

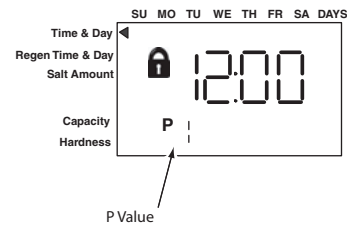

To change a setting refer to Table 13.1.

**Table 13.1**

Action	Key	Duration	Display
Enter basic programming	SET	Press and Release	Shows time and day of week
Move to desired display	UP or DOWN arrows	Press and Release	Increments through the displays
Enable setting to be changed	SET	Press and Release	Display flashes
Change setting	UP or DOWN arrows	Press and Release	Value changes and continues to flash
Save setting	SET	Press and Release	Display stops flashing
Return to operation	REGEN	Press and Release	Normal operation display
View history values	SET and DOWN	Press and Hold for 5 seconds	HO is displayed
Level II Advanced Programming	UP and DOWN	Press and Hold for 5 seconds	P1 is displayed

The 742/762 features a special programming level that allows the installing dealer to make changes to the control for more demanding applications. The home owner/end user should never have to access this level.

Level II menus include:

- P1 = Time of day
- P2 = Day of week
- P3 = Time of regeneration
- P4 = Number of days between regeneration (99 day calendar override)
- P5 = Not used (742 only)
- P6 = Amount of regenerant used per regeneration or filter backwash time (salt setting)
- P7 = System capacity
- P8 = Hardness
- P9 = Units of measure
- P10 = Clock mode
- P11 = Service interval
- P12 = Remote regeneration switch delay
- P13 = Refill sensor control (conditioner only)
  - 0 = Off
  - 1 = Salt detector only
  - 2 = Chlorine generation
- P14 = Refill rate (conditioner only)
- P15 = Draw rate (conditioner only)
- P16 = Reserve type
- P17 = Initial average or fixed reserve
- P18 = Flow sensor select
- P19 = K-factor or pulse equivalent

See the Logix Professional dealers manual for further details on setting Level II parameters.

**Table 13.2 Level I Parameters for 742/762 Single Tank Conditioner Systems**

	<b>Parameter Description</b>	<b>Range of Values</b>	<b>Minimum Increment</b>	<b>Default</b>	<b>Units of Measure</b>	<b>Notes</b>
P1	Time of Day	1:00 - 12:59 AM or PM 0:00 - 23:59	1 minute	12:00 PM	hour: minute	Range depends on value selected for P10
P2	Day of Week	N/A	1 day	None	N/A	Uses arrows under days of week on overlay.
P3	Time of Regeneration	1:00 - 12:59 AM or PM 0:00 - 23:59	1 minute	2:00 AM	hour: minute	Range depends on value selected for P10
P4	Calendar Override	0-99	1	3	days	0 = no calendar override, .5 = regeneration twice a day at time of regeneration and 12 hours later. Calendar Override skipped if at least one Day of Regeneration selected. Can be locked out of changes in Level 1 programming
P5	Day of Week Regeneration	N/A	1 day	None	N/A	Uses bars under days of week on overlay. Day of Week Regeneration is skipped if calendar override is more than zero. 742 only.
P6	Salt Setting	3-18 50-290	1 varies	9 110	lbs/Ft <sup>3</sup> grams/liter	Unit of measure depends on value in P9
P7	Capacity of unit (demand only)	1-900 .1-90.0	1 .1	(1)	kilograins kilograms	Unit of measure depends on value selected for P9.
P8	Hardness of water	3-200 30-2000	1 10	25 400	grains per gallon grams per liter	Unit of measure depends on value selected for P9. 762 mode only.
Notes: (1) calculated depending on salt setting and resin volume. Capacity may be manually adjusted.						

**Table 13.3 Level II Parameters for 742/762 Single Tank Conditioner Systems**

	Parameter Description	Range of Values	Minimum Increment	Default	Units of Measure	Notes
P9	Units of measure	0-1	1	(2)		0 = US, 1 = Metric
P10	Clock mode	0-1	1	(2)		0 = 12 hour clock, 1 = 24 hour clock
P11	Service Interval	0-250	1	0	months	Uses 30 days for each month.
P12	Remote Regeneration	3-250	1	0	months	Time remote switch must be active to start regeneration on 742 time clock units.
P13	Chlorine Generator Options	0-2	1	0		0 = No Chlorine Generator 1 = Salt check only 2 = Generate Chlorine
P14	Refill Rate	1-700	1	(1)	gpm x 100	
P15	Draw Rate	1-700	1	(1)	gpm x 100	
P16 (3)	Reserve Type	0-3	1	0		0 = Variable reserve delayed regeneration 1 = Fixed reserve delayed regeneration 2 = Variable reserve immediate regeneration 3 = Fixed reserve immediate regeneration
P17 (3)	Initial average or fixed reserve	0-70	1	30	% of Capacity	Depends on value entered in P16
P18 (3)	Flow sensor select	0-5	1	(1)		0 = Internal magnum NHWB, 1=1" Autotrol turbine, 2=2" Autotrol turbine, 3=User define K-Factor, 4=User defined Pulse Equivalent, 5=Internal Magnum HWB
P19 (3)	K-Factor or Pulse Equivalent	1.00-99.99 0-9999	0.01 1	0.01 1		K-Factor P18=3; Pulse Equivalent P18-4

Notes: (1) default selected with valve type and resin volume. (2) Factory Default is "0" for North America units and "1" for World Units. (3) P16 through P19 skipped on 742 time clock units.

**Table 13.4 Level I Parameters for 742/762 Single Tank 3 Cycle Filter Systems**

	<b>Parameter Description</b>	<b>Range of Values</b>	<b>Minimum Increment</b>	<b>Default</b>	<b>Units of Measure</b>	<b>Notes</b>
P1	Time of Day	1:00 - 12:59 AM or PM 0:00 - 23:59	1 minute	12:00 PM	hour: minute	Range depends on value selected for P10
P2	Day of Week	N/A	1 day	None	N/A	Uses arrows under days of week on overlay.
P3	Time of Regeneration	1:00 - 12:59 AM or PM 0:00 - 23:59	1 minute	2:00 AM	hour: minute	Range depends on value selected for P10
P4	Calendar Override	0-99	1	3	days	0 = no calendar override, .5 = regeneration twice a day at time of regeneration and 12 hours latter. Calendar Override skipped if at least one Day of Regeneration selected. Can be locked out of changes in Level 1 programming
P5	Day of Week Regeneration	N/A	1 day	None	N/A	Uses bars under days of week on overlay. Day of Week Regeneration is skipped if calendar override is more than zero. 742 only.
P6	Backwash Time (3 cycle filter mode)	1-250	0	14		Minutes of backwash in 3 cycle filter mode. Uses the arrow that points to salt amount on control in softener mode.
P7	Capacity of unit (demand only)	100-90,000 1-900	100 1	(1)	gallons M <sup>3</sup>	Unit of measure depends value selected for P9.
P8	Skipped					
Notes: (1) default selected with valve type and resin volume.						

**Table 13.5 Level II Parameters for 742/762 Single Tank 3 Cycle Filter Systems**

	<b>Parameter Description</b>	<b>Range of Values</b>	<b>Minimum Increment</b>	<b>Default</b>	<b>Units of Measure</b>	<b>Notes</b>
P9	Units of measure	0-1	1	(2)		0 = US, 1 = Metric
P10	Clock mode	0-1	1	(2)		0 = 12 hour clock, 1 = 24 hour clock
P11	Service Interval	0-250	1	0	months	Uses 30 days for each month.
P12	Remote Regeneration	3-250	1	60	seconds	Time remote switch must be active to start regeneration on 742 time clock units.
P13	Skipped					
P14	Skipped					
P15	Skipped					
P16 (3)	Reserve Type (demand only)	0-3	1	0		0 = Variable reserve delayed regeneration 1 = Fixed reserve delayed regeneration 2 = Variable reserve immediate regeneration 3 = Fixed reserve immediate regeneration
P17 (3)	Initial average or fixed reserve (demand only)	0-70	1	30	% of Capacity	Depends on value entered in P16
P18 (3)	Flow sensor select (demand only)	0-5	1	(1)		0 = Internal magnum NHWB, 1=1" Autotrol turbine, 2=2" Autotrol turbine, 3=User define K-Factor, 4=User defined Pulse Equivalent, 5=Internal Magnum HWB
P19 (3)	K-Factor or Pulse Equivalent	1.00-99.99 0-9999	0.01 1	0.01 1		K-Factor P18=3; Pulse Equivalent P18-4
Notes: (1) default selected with valve type and resin volume. (2) Factory Default is "0" for North America units and "1" for World Units. (3) P16 through P19 skipped on 742 time clock units.						

## 14.0 Cycle Time Programming

Cycle times may be viewed by pressing and holding the UP and SET keys for 5 seconds when the control is in the "in service mode". The display shows the small "C" in the lower portion of the display indicating the control is in cycle times programming. Pressing the UP and DOWN keys displays the programmed time remaining in each cycle. Pressing the REGENERATION key exits the cycle times display mode.

The programmed cycle time may be changed by pressing the SET key while a programmed cycle time is displayed. The cycle time in minutes flashes indicating it can be changed. Pressing the UP or DOWN keys changes the flashing time. Pressing the SET key while the cycle time is flashing enters the flashing value displayed in the displayed cycle number. The draw and refill cycle times cannot be changed in cycle time programming for conditioner valves. Draw and refill times are calculated using the draw and refill rates and salt amounts. The draw and refill cycle times may be programmed for 3 cycle filters.

**Table 14.1 Cycle Times**

Magnum Valves 293/298		
Description	Default (min)	C# Displayed
1-Backwash	14	1
2-Draw (1)	(3)	2 (2)
3-Slow Rinse	(4)	3 (2)
5-Fast Rinse	6	5
8-Refill (1)	(5)	8

(1) Draw and Refill times are calculated on a conditioner valve using the draw and refill rates and salt setting. Draw and Refill times may be programmed in minutes on the 3 cycle filter valve. See Section 11.1 *Special Applications*.

(2) Separate draw and rinse positions are present on Magnum cam. Control stays in the brine draw position for both the draw and rinse times then proceeds through the rinse position with no dwell time.

(3) Depends on valve type and resin volume. Time calculated from total salt amount and draw rate.

(4) Depends on valve type, resin volume, and rinse rate. Time calculated for 2.0 bed volumes on 298 valves.

(5) Depends on valve type and resin volume. Time calculated from total salt amount and refill rate.



## 15.0 Accessing History Values

The 742/762 features a review level that displays the operation history of the system. This is a great troubleshooting tool for the control valve.

To access history values, press and hold SET and DOWN for five seconds to view the "H" levels.

### History Values

	Description	Range	Notes
H0	Initial setting value	Cubic feet or liters	Resin volume
H1	Days since last regeneration	0 - 255	
H2	Current flow rate	Depends on turbine used	762 only
H3	Water used today in gallons/m <sup>3</sup> since Time of Regeneration	0 - 131,070 gallons or 0 - 61,310.70 m <sup>3</sup>	762 only
H4	Water used since last regeneration in gallons/m <sup>3</sup>	0 - 131,070 gallons or 0 - 61,310.70 m <sup>3</sup>	762 only
H5	Total water used since reset in 100s	0 - 999,900 gallons or 0 - 9,999 m <sup>3</sup>	762 only
H6	Total water used since reset in 1,000,000	4,294 × 10 <sup>6</sup> gal or 4,264 × 10 <sup>4</sup> m <sup>3</sup>	762 only
H7	Average usage for Sunday in gallons or m <sup>3</sup>	0 - 131,070 gallons or 0 - 61,310.70 m <sup>3</sup>	762 only
H8	Average usage for Monday in gallons or m <sup>3</sup>	0 - 131,070 gallons or 0 - 61,310.70 m <sup>3</sup>	762 only
H9	Average usage for Tuesday in gallons or m <sup>3</sup>	0 - 131,070 gallons or 0 - 61,310.70 m <sup>3</sup>	762 only
H10	Average usage for Wednesday in gallons or m <sup>3</sup>	0 - 131,070 gallons or 0 - 61,310.70 m <sup>3</sup>	762 only
H11	Average usage for Thursday in gallons or m <sup>3</sup>	0 - 131,070 gallons or 0 - 61,310.70 m <sup>3</sup>	762 only
H12	Average usage for Friday in gallons or m <sup>3</sup>	0 - 131,070 gallons or 0 - 61,310.70 m <sup>3</sup>	762 only
H13	Average usage for Saturday in gallons or m <sup>3</sup>	0 - 131,070 gallons or 0 - 61,310.70 m <sup>3</sup>	762 only
H14	Average service cycle	0 - 255 days	762 only
H15	Peak flow rate	0 - 200 gpm or 1,000 Lpm	762 only
H16	Day and time of peak flow rate	Time and day that peak flow occurred	762 only
H17	Months since service	0 - 2,184 months	

---

## 16.0 Control Reset

To reset the control:

1. Press and hold SET and DOWN simultaneously for 5 seconds.
2. H0 and the system's set resin volume (or "F" mode) is displayed.
3. If a history value other the "H0" is displayed, use the UP button to scroll through the settings until "H0" is displayed.
4. To reset the control, press and hold SET for 5 seconds.
5. The control is reset to an unprogrammed state.
6. Go to "Initial Set-up" section to reprogram control.



**WARNING:**Resetting the control deletes all information stored in its memory, except time and day. This requires you to reprogram the control completely from the initial power-up mode.

## 17.0 Troubleshooting

### 17.1 Troubleshooting: Logix Controller

Problem	Possible Cause	Solution
ERR 1 is displayed	Controller power has been connected and the control is not sure of the state of the operation.	Press the UP arrow and the control should reset.
ERR 2 is displayed	Controller power does not match 50 or 60 Hz.	Disconnect and reconnect the power. If problem persists, obtain the appropriate controller or AC adapter for either 50 or 60 Hz power.
ERR 3 is displayed	Controller does not know the position of the camshaft. Camshaft should be rotating to find Home position.	Wait for two minutes for the controller to return to Home position. The hourglass should be flashing on the display indicating the motor is running.
	Camshaft is not turning during ERR 3 display.	Check that motor is connected. Verify that motor wire harness is connected to motor and controller module. Verify that optical sensor is connected and in place. Verify that motor gear has engaged cam gear. If everything is connected, try replacing in this order: <ul style="list-style-type: none"> <li>—Wire harness</li> <li>—Motor</li> <li>—Optical sensor</li> <li>—Controller</li> </ul>
	If camshaft is turning for more than five minutes to find Home position:	Verify that optical sensor is in place and connected to wire. Verify that camshaft is connected appropriately. Verify that no dirt or rubbish is clogging any of the cam slots. If motor continues to rotate indefinitely, replace the following components in this order: <ul style="list-style-type: none"> <li>—Wire harness</li> <li>—Motor</li> <li>—Optical sensor</li> <li>—Controller</li> </ul>
Four dashes displayed: — : —	Power failure of more than 8 hours has occurred	Press SET to reset the time display.

## 17.2 Troubleshooting: Magnum IT and Cv Valve

Symptom	Possible Cause	Solution
1. Water conditioner fails to regenerate. No soft water.	<ul style="list-style-type: none"> <li>a. Power supply to Magnum control has been interrupted.</li> <li>b. Water pressure lost.</li> <li>c. Logix control improperly programmed.</li> <li>d. Defective control.</li> <li>e. No salt in brine tank.</li> <li>f. Manual bypass valve is open.</li> <li>g. For 762 series control, turbine meter is clogged or restricted.</li> <li>h. Leak at riser pipe seal.</li> <li>i. Insufficient brine.</li> <li>j. Plugged injector or injector screen.</li> </ul>	<ul style="list-style-type: none"> <li>a. Determine reason for power interruption and correct. Reset time of day.</li> <li>b. Restore water pressure.</li> <li>c. Verify that the Logix control is properly programmed.</li> <li>d. Replace control assembly.</li> <li>e. Add salt and regenerate.</li> <li>f. Close manual bypass valve.</li> <li>g. Inspect turbine meter assembly, clean or replace.</li> <li>h. Ensure that riser pipe is properly sealed at tank adapter O-ring. Inspect pipe for cracks.</li> <li>i. Check refill control and clean if necessary. Check control settings. Check flow rate capabilities of safety float and air check assembly.</li> <li>j. Inspect and clean injector and/or injector screen.</li> </ul>
2. No Brine Draw.	<ul style="list-style-type: none"> <li>a. Plugged injector or injector screen.</li> <li>b. Insufficient water pressure.</li> <li>c. Obstructed drain line.</li> <li>d. Brine line pulling air.</li> </ul>	<ul style="list-style-type: none"> <li>a. Inspect and clean injector and/or injector screen.</li> <li>b. Increase water pressure above 25 psig (172 kPa) minimum.</li> <li>c. Remove obstruction.</li> <li>d. Ensure all brine line fittings are tight.</li> </ul>
3. Insufficient brine draw.	<ul style="list-style-type: none"> <li>a. Partially clogged injector or injector screen.</li> <li>b. Restricted flow rate in brine line.</li> <li>c. Insufficient water pressure.</li> <li>d. Excessive back pressure on injector due to elevated drain line.</li> <li>e. Partially restricted drain line.</li> </ul>	<ul style="list-style-type: none"> <li>a. Inspect and clean injector and/or injector screen assembly.</li> <li>b. Check flow rate capabilities of the safety float/aircheck assembly.</li> <li>c. Increase water pressure above 25 psig (172kPa) minimum.</li> <li>d. Reduce drain line elevation to height of valve.</li> <li>e. Remove restriction.</li> </ul>
4. Insufficient Refill to Brine Tank.	<ul style="list-style-type: none"> <li>a. Restricted flow rate in brine line.</li> <li>b. Resin volume incorrectly set.</li> </ul>	<ul style="list-style-type: none"> <li>a. Check flow rate capabilities of the safety float/aircheck assembly.</li> <li>b. Reprogram.</li> </ul>
5. Excessive Water in Brine Tank.	<ul style="list-style-type: none"> <li>a. Plugged drain line flow control.</li> <li>b. Plugged injector and/or injector screen.</li> <li>c. Incorrect refill control.</li> <li>d. Insufficient water pressure.</li> </ul>	<ul style="list-style-type: none"> <li>a. Clean flow control.</li> <li>b. Inspect and clean injector and/or screen.</li> <li>c. Install correct control.</li> <li>d. Ensure that operating pressure is above 25 psi.</li> </ul>
6. Leak to Main Drain.	<ul style="list-style-type: none"> <li>a. No flow control installed in drain line.</li> <li>b. Insufficient water pressure.</li> <li>c. Plugged injector and/or injector screen.</li> <li>d. Back pressure on pilot drain port.</li> </ul>	<ul style="list-style-type: none"> <li>a. Install drain line flow control.</li> <li>b. Increase water pressure above 25 psig (172 kPa) minimum.</li> <li>c. Inspect and clean injector and/or injector screen.</li> <li>d. Plumb pilot drain line to atmospheric position (i.e. brine tank).</li> </ul>

Symptom	Possible Cause	Solution
7. Loss of Media to Drain.	<ul style="list-style-type: none"> <li>a. No flow control installed in drain line.</li> <li>b. Air or gasses in raw water.</li> <li>c. Unit draws air through brine line.</li> <li>d. Defective air check.</li> </ul>	<ul style="list-style-type: none"> <li>a. Install drain line flow control.</li> <li>b. Ensure that air or gasses are not present in feed water.</li> <li>c. Ensure that all brine line fittings are tight and that the aircheck closes.</li> <li>d. Clean or replace aircheck.</li> </ul>
8. Loss of Water Pressure.	<ul style="list-style-type: none"> <li>a. Fouled resin bed due to iron accumulation.</li> <li>b. Slots in riser pipe or laterals are filled with resin fines.</li> </ul>	<ul style="list-style-type: none"> <li>a. Clean Magnum control valve and mineral bed with cleaner.</li> <li>b. Inspect and clean distributor pipe slots as needed.</li> </ul>
9. Salt in Water to Service After Regeneration.	<ul style="list-style-type: none"> <li>a. Injector is too small for system size.</li> <li>b. Brine draw time excessively long due to low water pressure.</li> <li>c. Restricted drain line.</li> <li>d. Insufficient rinse volume.</li> <li>e. Plugged injector and/or injector screen.</li> </ul>	<ul style="list-style-type: none"> <li>a. Install correct injector.</li> <li>b. Increase water pressure above 25 psig (172 kPa) minimum.</li> <li>c. Remove drain line restriction.</li> <li>d. Increase slow rinse time, fast rinse time, or both.</li> <li>e. Inspect and clean injector and/or injector screen.</li> </ul>
10. Err1, Err2, Err3.	<ul style="list-style-type: none"> <li>a. See Logix Series Troubleshooting.</li> </ul>	<ul style="list-style-type: none"> <li>a. See Logix Series Troubleshooting.</li> </ul>

### 17.3 Magnum Valve Cartridge Troubleshooting

This procedure provides sequential troubleshooting steps to isolate a suspect cartridge. Figure 17.1 displays the locations of all cartridges.

**NOTE:** The Dynamic Pressure applied to the valve must be greater than 25 psi at all times when performing the following tests. If a cartridge needs to be removed, follow the cartridge removal procedure in Section 18.0.

There are four symptoms that may require a cartridge to be removed and inspected or replaced.

1. A constant leak from the pilot drain in any cycle position. A small discharge of water from the pilot drain while transitioning from one cycle to the next is normal. A leak from the pilot drain could be caused by the following:
  - a. Diaphragm failure in one of the valve cartridges. See Table 17.1 for troubleshooting faulty cartridges.
  - b. Debris may prevent the flappers from closing.

Inspect discs and seats.

**Table 17.1 Troubleshooting Faulty Cartridges**

Quick cycle the Logix Magnum to each cycle indicated below. If the leak stops in a particular cycle, remove the cartridge listed in the right column. Inspect for wear or damage.	
No Leak During	Cartridge
Service Cycle	#3 Outlet
Backwash	#1 Drain
Brine/Slow Rinse	#2 Rinse
Fast Rinse	#2 Rinse or #4 Inlet

2. A leak to the main 1.5-inch drain valve port.
  - a. If the system is newly installed, ensure that the start-up procedure has been properly followed. Refer to the Service Manual or the start up sheet packed in the shipping carton of the Magnum valve.
  - b. If the system has been operating correctly for a period of time and is now leaking, see Table 17.2.

**Table 17.2 Magnum Valve Leak to Main Drain Troubleshooting**

Regenerate the unit if the media bed is exhausted, then proceed to the following steps:
1. Test the water leaking from the 1.5-inch drain port of the Magnum valve. If it is treated, remove and inspect the #2 Rinse cartridge.
2. If the water leaking to the 1.5-inch drain port is untreated, remove and inspect the #1 Drain cartridge.

3. Leakage of untreated water to service.
  - a. Leak at riser pipe seal or any other cause mentioned in Service Manual.
  - b. Bypassing of untreated water by #4 Inlet cartridge, remove and inspect.
4. Leak between the main valve body and the cartridge assembly.
  - a. Remove and replace the two small O-rings at the 5:30 and 6:30 positions of the cartridge. The part number for the O-ring set is P/N 1010116.

**NOTE:** Replacement cartridges are only available as complete assemblies:

Cartridge #1	Drain	P/N 1000366
Cartridge #2	Fast Rinse	P/N 1000365
Cartridge #3	Service	P/N 1000366 (No bypass)
Cartridge #3	Service	P/N 1000336 (Cap only for bypass)
Cartridge #4	Inlet	P/N 1000317

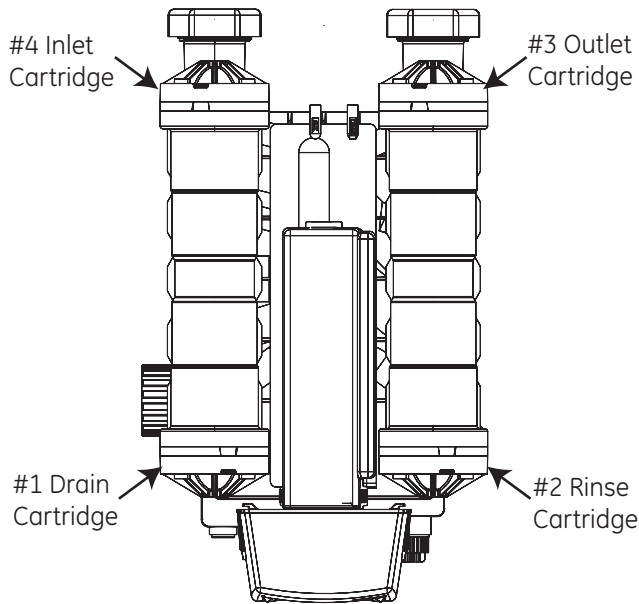

Figure 17.1 Logix Magnum Control

## 18.0 Magnum Valve Cartridge Removal Procedure

Removal of cartridges should be done only after reviewing all other possible causes of the problem(s) being addressed. There may be some difficulty removing cartridges in valves that have been in service for a period of time. Scale or iron build up around the O-ring seals may cause breakage in the cage assembly of the cartridge. If this occurs the cartridge must be replaced.

To remove the number 1 or number 2 cartridges the control must be removed first (see Assembly instruction in the Magnum instruction manual, Section 2.1).

What follows is a step-by-step procedure for cartridge removal:

1. Remove the four bolts securing the cartridge.
2. There are two parts or sections in the "cap" of the cartridge assembly. The first part is the cover for the diaphragm. The second part is attached to the main cartridge assembly. This part is in contact with the body of the Magnum valve. When referring to inserting screwdrivers for cartridge removal it is the area between the Magnum valve body and the second part of the cartridge that is being referred to. See Figure 18.1.
3. A small flat blade screwdriver should be inserted as indicated in drawing. Pry a small opening between the Magnum valve body and the second part of the cartridge. This allows the insertion of two larger flat blade screwdrivers that are used to remove the cartridge.
4. Insert the two larger flat blade screwdrivers at the 10 o'clock and 2 o'clock positions on the cartridge. These should be inserted approximately 1/2 inch into the opening created by the small blade screwdriver. Use the two screwdrivers to slowly move the cartridge out of the valve body.
5. The cartridge should be removed for inspection. Look for damaged O-ring or debris on sealing surface ring of poppet.

There are two nipples, one on either side of the bottom center on the inside of the cartridge cap. They transfer water to and from the diaphragm. There are two O-rings associated with the nipples. The O-rings must be in place when the cartridge is re-installed into the valve body.

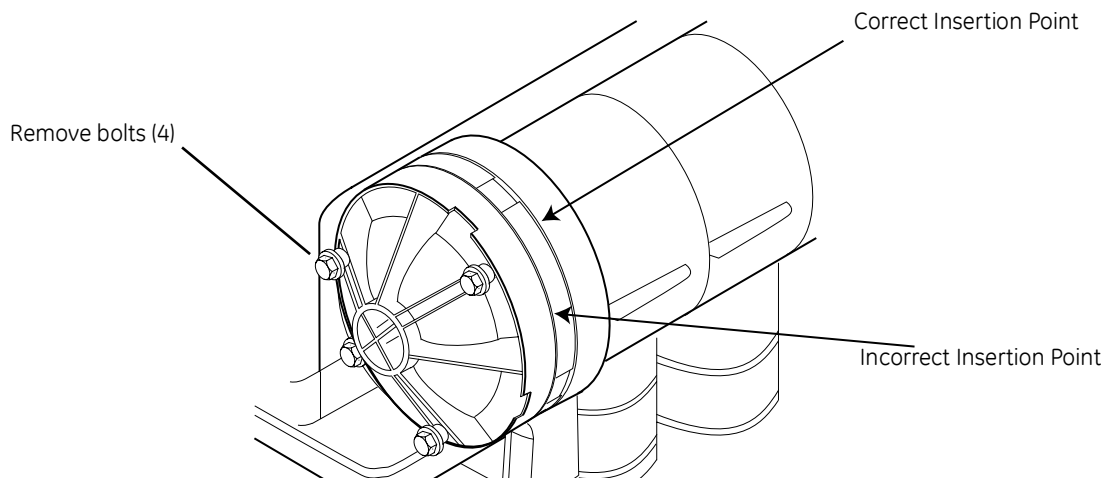
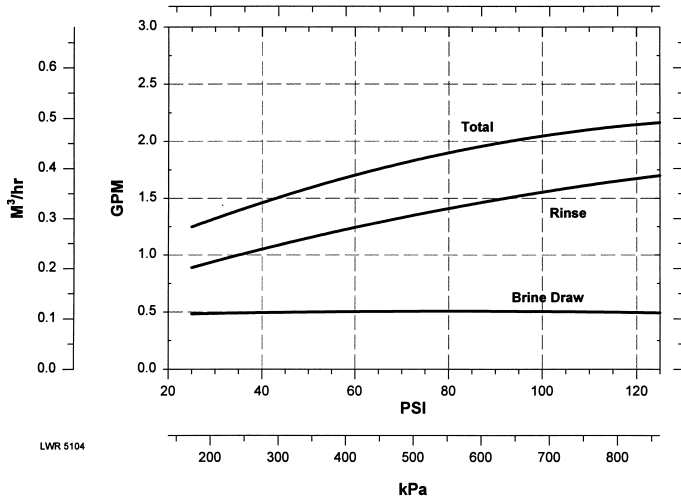

Figure 18.1

# 19.0 Performance Injectors

## 19.1 Injector Charts

**Injector # 1000441**  
Typical for 14-inch Tank\*



LWR 5104

**Injector # 1000442**  
Typical for 16-inch Tank\*

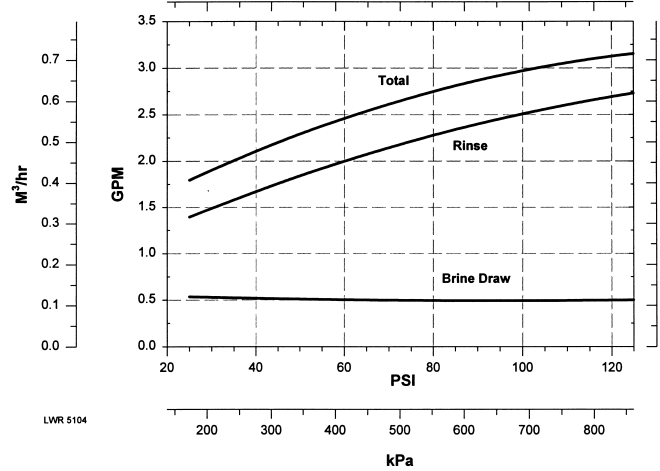

LWR 5104

**Injector # 1000443**  
Typical for 18-inch Tank\*

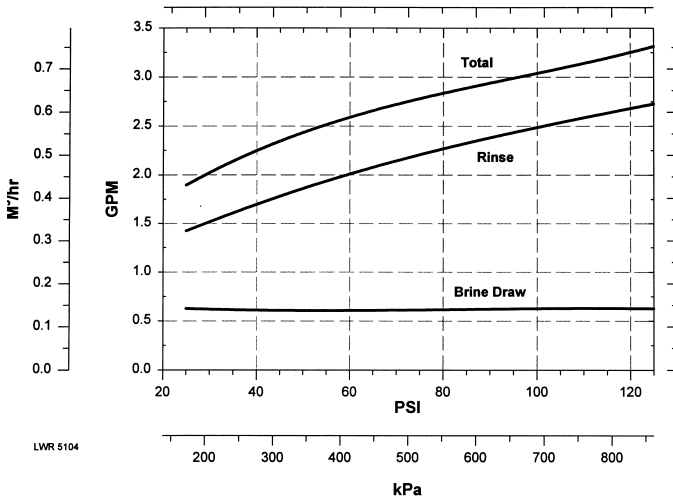

LWR 5104

**Injector # 1000444**  
Typical for 21-inch Tank\*

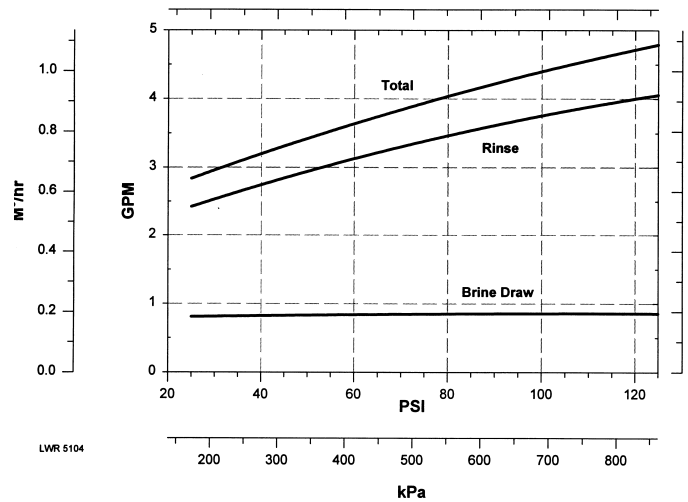

LWR 5104



**Injector # 1000445**  
Typical for 24-inch Tank\*

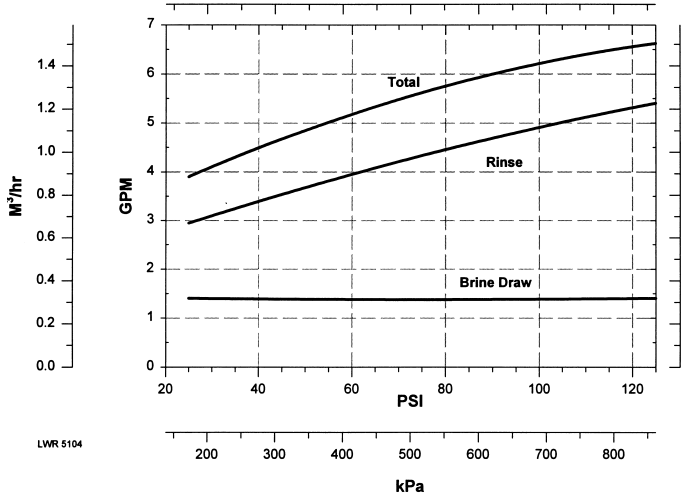

LWR 5104

**Injector # 1000446**  
Typical for 30-inch Tank\*

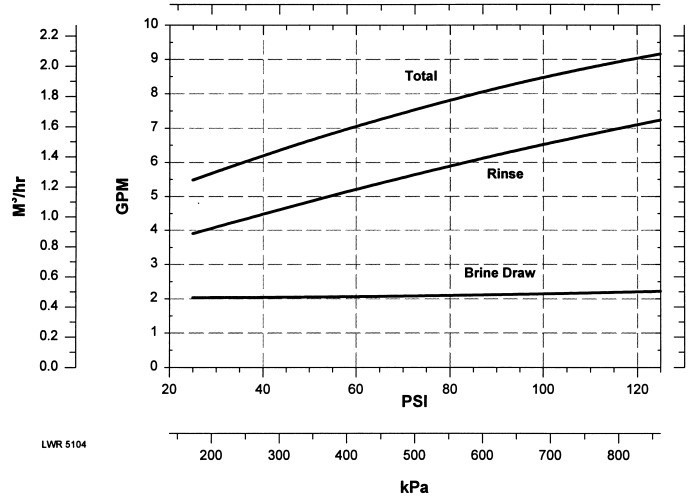

LWR 5104

**Injector # 1000447**  
Typical for 36-inch Tank\*

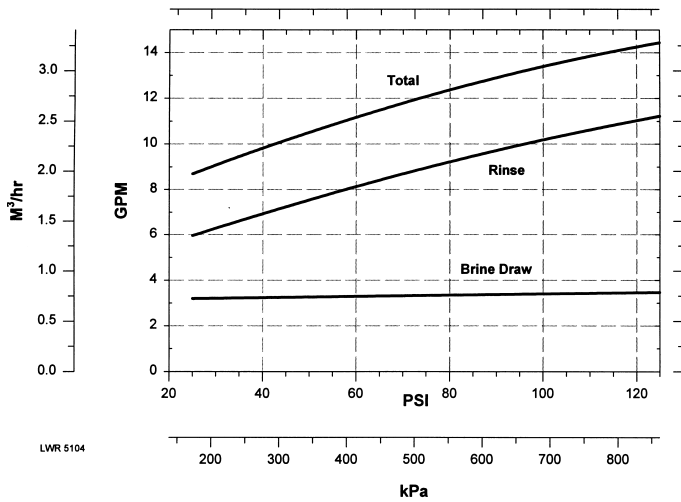

LWR 5104

\*Brine draw and Rinse rates on empty tank.

## 19.2 Magnum Injector Controls

### Injector Identification

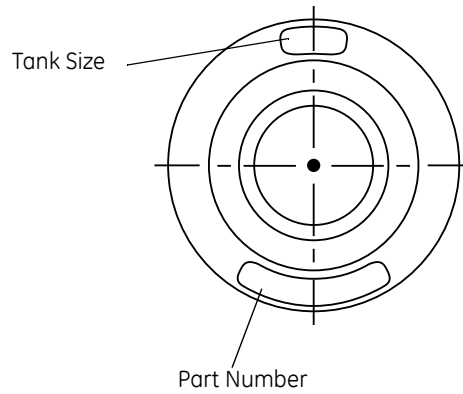
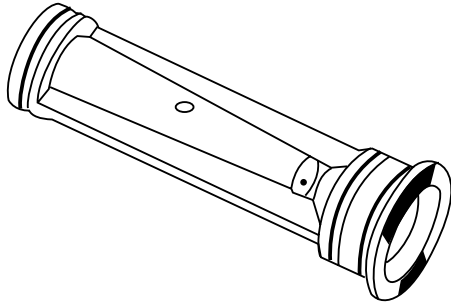

**Table-1 Magnum Injector Chart**

Part Number	Part Number with O-rings	Tank Diameter In. (cm)	Draw Rate GPM (LPM)
1000441	1040670	14 (35.6)	0.5 (1.89)
1000442	1040671	16 (40.6)	0.5 (1.89)
1000443	1040672	18 (45.7)	0.6 (2.27)
1000444	1040673	21 (53.3)	0.9 (3.41)
1000445	1040674	24 (61.0)	1.4 (5.30)
1000446	1040675	30 (76.2)	2.0 (7.57)
1000447	1040676	36 (91.4)	3.3 (12.5)
1000448*	1040677	Blank	0.0

**NOTE:** All flow rates are based on an inlet pressure of 60 psig (413 kPa). Actual rates vary with pressure, temperatures and other system variables.

\*Filter applications only.

---

---

## 20.0 Magnum Flow Controls

### 20.1 Refill Control Identification

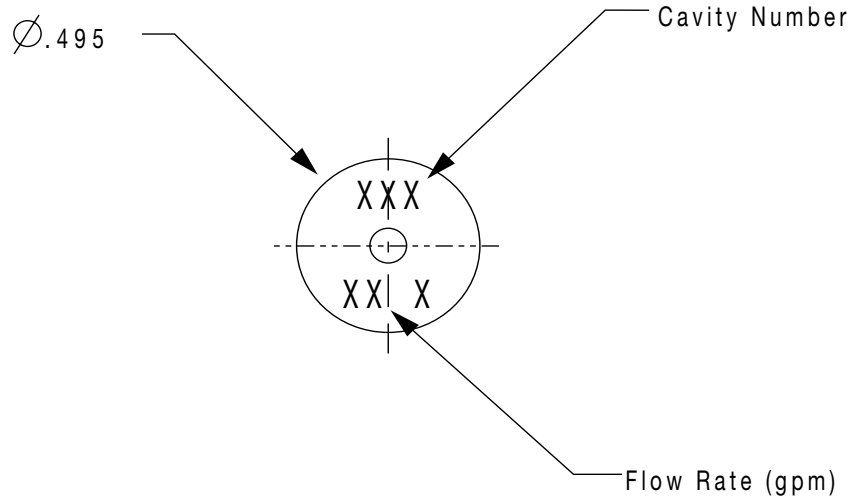

**Table 20.1 Magnum Refill Control Chart**  
(P/N Indicates 3-Pack)

Part Number	Tank Diameter In. (cm)	Flow Rate GPM (LPM)
1040679	14 (35.6)	0.7 (2.65)
1040680	16 (40.6)	0.8 (3.03)
1040681	18 (45.7)	1.0 (3.79)
1040682	21 (53.3)	1.4 (5.30)
1040683	24 (61.0)	2.0 (7.57)
1040684	30 (76.2)	3.0 (11.36)
1040685	36 (91.4)	5.0 (18.93)

**NOTE:** All flow rates are based on an inlet pressure of 60 psig (413 kPa). Actual rates vary with pressure, temperatures and other system variables.

## 20.2 Drain Line Flow Control

Table 20.2 Drain Line Flow Controls (5 gpm - 40 gpm)

Part Number	Flow Control Disk		Insert 1	Insert 2	Insert 3	Insert 4
	gpm	m <sup>3</sup> /h				
1040720	5	1.135	Blue	Black	Black	Black
1040721	6	1.362	Red	Black	Black	Black
1040722	7	1.589	Brown	Black	Black	Black
1040723	8	1.816	Green	Black	Black	Black
1040724	9	2.043	White	Black	Black	Black
1040725	10	2.27	Blue	Blue	Black	Black
1040726	11	2.497	Red	Blue	Black	Black
1040727	12	2.724	Red	Red	Black	Black
1040728	13	2.951	Brown	Red	Black	Black
1040729	14	3.178	Brown	Brown	Black	Black
1040740	15	3.405	Blue	Blue	Blue	Black
1040741	16	3.632	Green	Green	Black	Black
1040742	17	3.859	White	Green	Black	Black
1040743	18	4.086	White	White	Black	Black
1040744	19	4.313	White	Orange	Black	Black
1040745	20	4.54	Blue	Blue	Blue	Blue
1040746	21	4.767	Brown	Brown	Brown	Black
1040747	22	4.994	Green	Green	Red	Black
1040748	23	5.221	Green	Green	Brown	Black
1040749	24	5.448	Red	Red	Red	Red
1040730	25	5.675	Green	Green	White	Black
1040731	26	5.902	White	White	Green	Black
1040732	27	6.129	White	White	White	Black
1040733	28	6.356	Brown	Brown	Brown	Brown
1040734	29	6.583	Brown	Brown	Brown	Green
1040735	30	6.81	Orange	Orange	Orange	Black
1040736	31	7.037	Green	Green	Green	Brown
1040737	32	7.264	Green	Green	Green	Green
1040738	33	7.491	Green	Green	Green	White
1040739	34	7.718	Green	Green	Green	Orange
1040750	35	7.945	White	Green	Green	Green
1040751	36	8.172	White	White	White	White
1040752	37	8.399	White	White	White	Orange
1040753	38	8.626	Orange	Orange	Orange	Green
1040754	39	8.853	Orange	Orange	Orange	White
1040755	40	9.08	Orange	Orange	Orange	Orange

**NOTE:** Drain Line Flow Controls above 40 gpm require external control installed in drain line.

## 20.3 Recommended Backwash Flow Rates for Various Media

Table 20.3 Recommended Backwash Flow Rates for Various Media

Media	Tank Diameter						
	14 in (35.6 cm) Tank	16 in (40.6 cm) Tank	18 in (45.7 cm) Tank	21 in (53.3 cm) Tank	24 in (61.0 cm) Tank	30 in (76.2 cm) Tank	36 in (91.4 cm) Tank
	Drain Line Flow Control in GPM						
*Softening Resin (5.0 gpm/ft <sup>2</sup> ) (12.25 m/h/cm <sup>2</sup> )	5	7	9	12	15	25	35
*Fine Mesh Softening Resin (2.8 gpm/ft <sup>2</sup> ) (6.86 m/h/cm <sup>2</sup> )	3	4	5	7	9	14	20
Multi Layer (15 gpm/ft <sup>2</sup> ) (36.75 m/h/cm <sup>2</sup> )	15	20	25	36	50	70	105
Birm, Greensand, Carbon (10 gpm/ft <sup>2</sup> ) (24.5 m/h/cm <sup>2</sup> )	10	15	17	25	30	50	70

\*50 °F (10°C) water temperature, 50% bed expansion

## 20.4 Logix Magnum It and Cv Exploded View

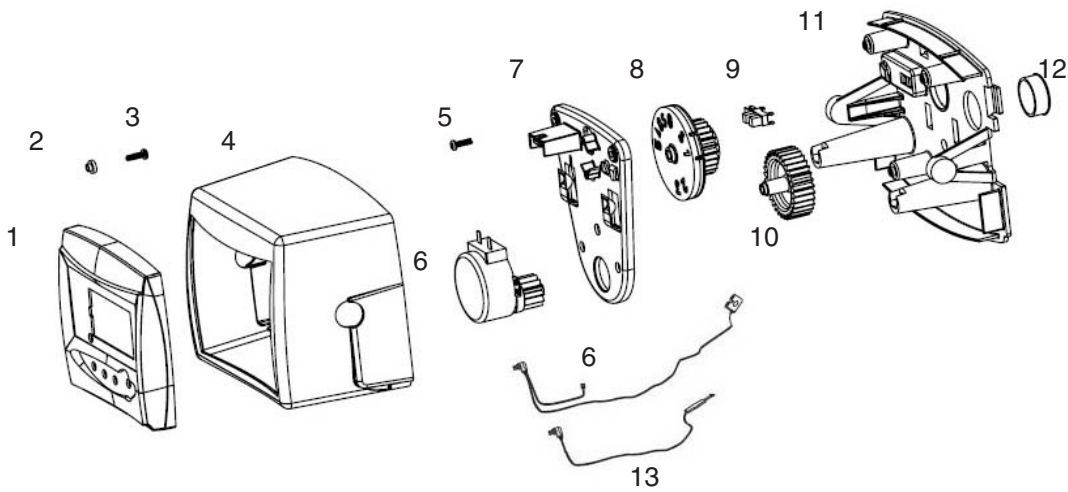

Item No.	Part Number - Kits	Part Number	Description	
1		3003191	Logix 742 Control, North American	
		3003193	Logix 742F Control, North American	
		3003197	Logix 762 Control, North American	
		3003199	Logix 762F Control, North American	
2		1266224	Bushing, Logix Mount	
3		1005981	Screw	
4		1262674	Cover, Logix Magnum	
5	1233809	1005981	Screw	
6		1235361	Motor, Logix Cable Assembly	
7		1262673	Gear Plate, Logix	
8		1262581	Drive Gear, Logix	
9		1235373	Optic Sensor	
10		1262672	Idler Gear, Logix	
11		1262580	Back Plate, Logix Magnum	
12		1239647	Bushing, Cable	
13			1266722	Meter Cable, 32 inches
			1266723	Meter Cable. 10 feet
		1266724	Meter Cable, 25 feet	
*		1000827	Outdoor Cover	
*		1263718	Remote Mount Kit, with 10 ft cable	
*		1256257	Remote Mount Kit, no extension cable	

## 21.0 Replacement Components: Logix Magnum Conditioner/Filters

### 21.1 Camshaft and Pilot Valve Assembly

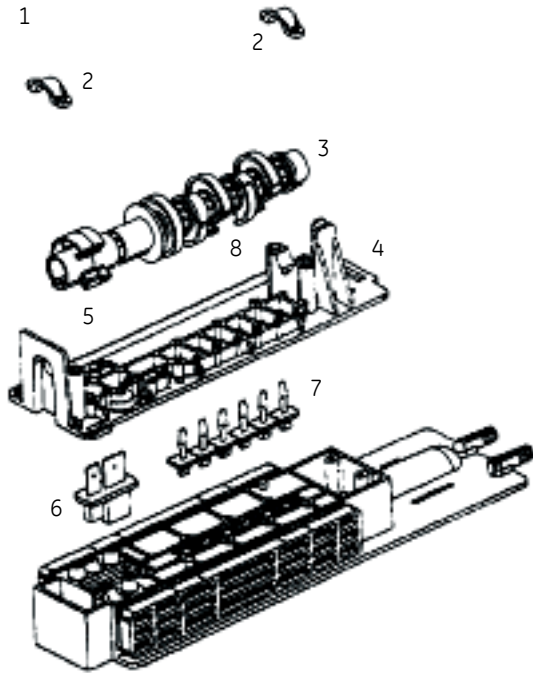

Figure 21.1

### 21.2 Camshaft Components

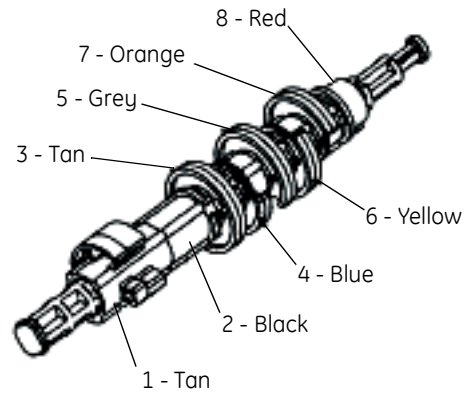

Figure 21.2

Table 21.1 Assembly Parts

Item Number	Part Number	Description
1	1006095	Screw, Pillow Block
2	1000589	Pillow Block
3	1267726	Logix Magnum Camshaft
4	1000339	Top Plate
5	1006093	Screw Short, Top Plate
6	1000391	Brine Valve Disc
7	1000328	Pilot Valve Disc
8	1006095	Screw Long, Top Plate

Table 21.2 Camshaft Components

Item Number	Part Number	Color
1	1000499	Tan
2	1000462	Black
3	1001620	Tan
4	1001621	Blue
5	1267724	Grey
6	1001623	Yellow
7	1001624	Orange
8	1000469	Red

## 21.3 Magnum Valve Cartridges

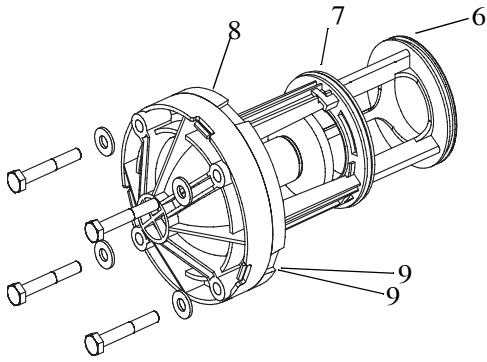

1 - Drain Valve Cartridge

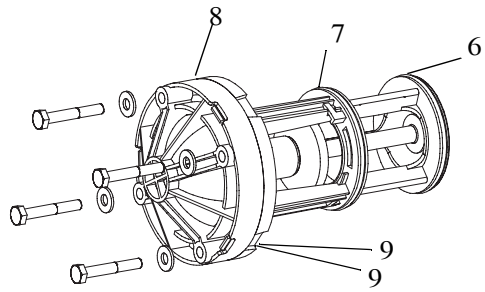

2 - Rinse Valve Cartridge

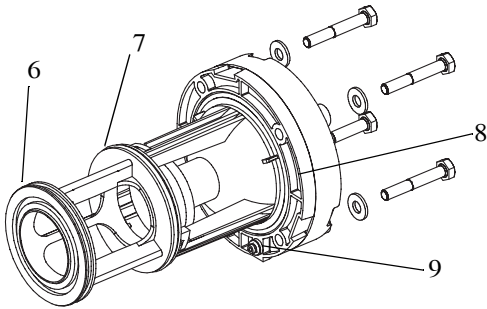

3 - No Hard Water Bypass Valve Cartridge

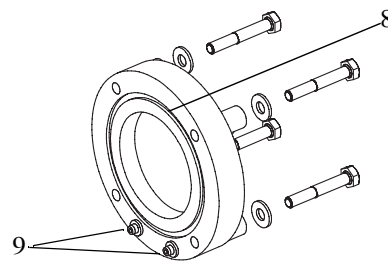

4 - Hard Water Bypass Cap

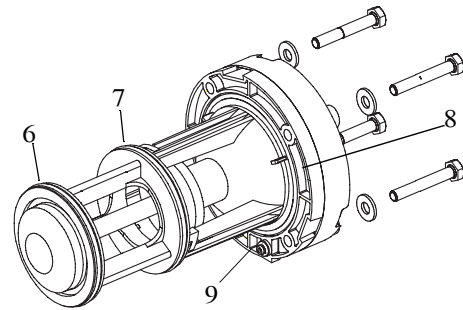

5 - Inlet Valve Cartridge

Item	Part Number	Description
1	1000366	Drain Valve Cartridge, Single Seat - Spring Assisted
2	1000365	Rinse Valve Cartridge, Double Seat - Spring Assisted
3	1000366	No Hardwater Bypass Valve Cartridge, Single Seat - Spring Assisted
4	1000336	Hardwater Bypass Cap
5	1000317	Inlet Valve Cartridge, Double Seat - No Spring Assist
6	1010157	O-Ring
7	1010158	O-Ring
8	1010159	O-Ring
9	1010116	O-Ring (qty. 2 per Cartridge)

**NOTE:**Items 1 and 3 are identical valve cartridges.



## 21.4 Injector Assembly

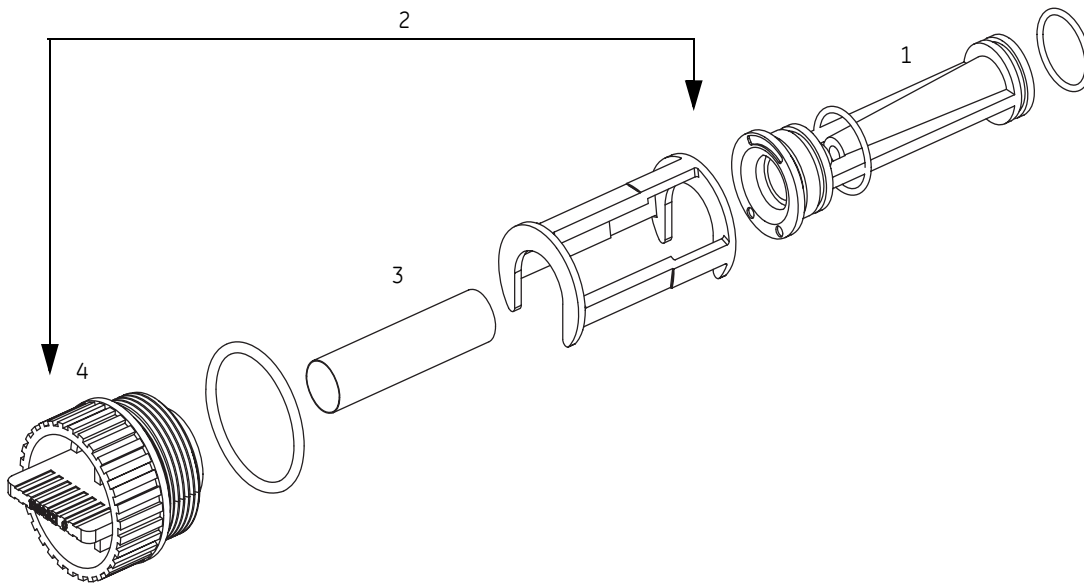

Item	Part Number	Description
1	1040670	Injector for 14-inch (35.6 cm) Tank - 0.5 GPM (1.9 LPM) (includes O-rings)
	1040671	Injector for 16-inch (40.6 cm) Tank - 0.5 GPM (1.9 LPM) (includes O-rings)
	1040672	Injector for 18-inch (45.7 cm) Tank - 0.6 GPM (2.27 LPM) (includes O-rings)
	1040673	Injector for 21-inch (53.3 cm) Tank - 0.9 GPM (3.41 LPM) (includes O-rings)
	1040674	Injector for 24-inch (61.0 cm) Tank - 1.4 GPM (5.3 LPM) (includes O-rings)
	1040675	Injector for 30-inch (76.2 cm) Tank - 2.0 GPM (7.57 LPM) (includes O-rings)
	1040676	Injector for 36-inch (91.4 cm) Tank - 3.3 GPM (12.5 LPM) (includes O-rings)
	1040669	Injector, Blank (includes O-rings)
2	1040677	Injector Assembly (Less Injector)
3	1040678	Injector Screen (3 pack)
4	1040688	Cap (including O-rings)

## 21.5 Refill Flow Control Assembly

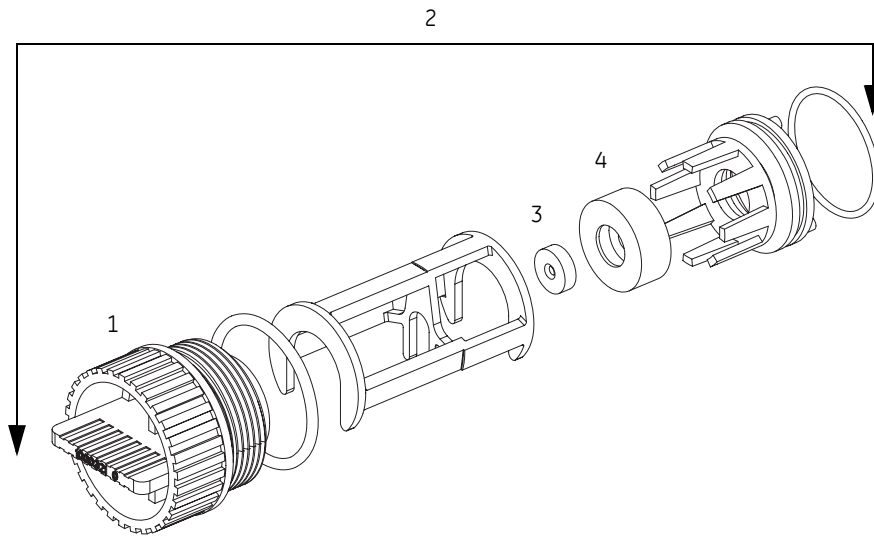

Item	Part Number	Description
1	1040688	Cap (includes O-ring)
2	1040687	Refill Assembly (Less Refill Flow Control)
3	1040679	Refill Flow Control for 14-inch (35.6 cm) Tank - 0.7 GPM (2.6 LPM) (3 pack)
	1040680	Refill Flow Control for 16-inch (40.6 cm) Tank - 0.8 GPM (3.0 LPM) (3 pack)
	1040681	Refill Flow Control for 18-inch (45.7 cm) Tank - 1.0 GPM (3.8 LPM) (3 pack)
	1040682	Refill Flow Control for 21-inch (53.3 cm) Tank - 1.4 GPM (5.3 LPM) (3 pack)
	1040683	Refill Flow Control for 24-inch (61.0 cm) Tank - 2.0 GPM (7.6 LPM) (3 pack)
	1040684	Refill Flow Control for 30-inch (76.2 cm) Tank - 3.0 GPM (11.4 LPM) (3 pack)
	1040685	Refill Flow Control for 36-inch (91.4 cm) Tank - 5.0 GPM (19.0 LPM) (3 pack)
4	1040686	Refill Flow Control Cage (3 pack)

## 21.6 Magnum IT Flow Sensor Assembly

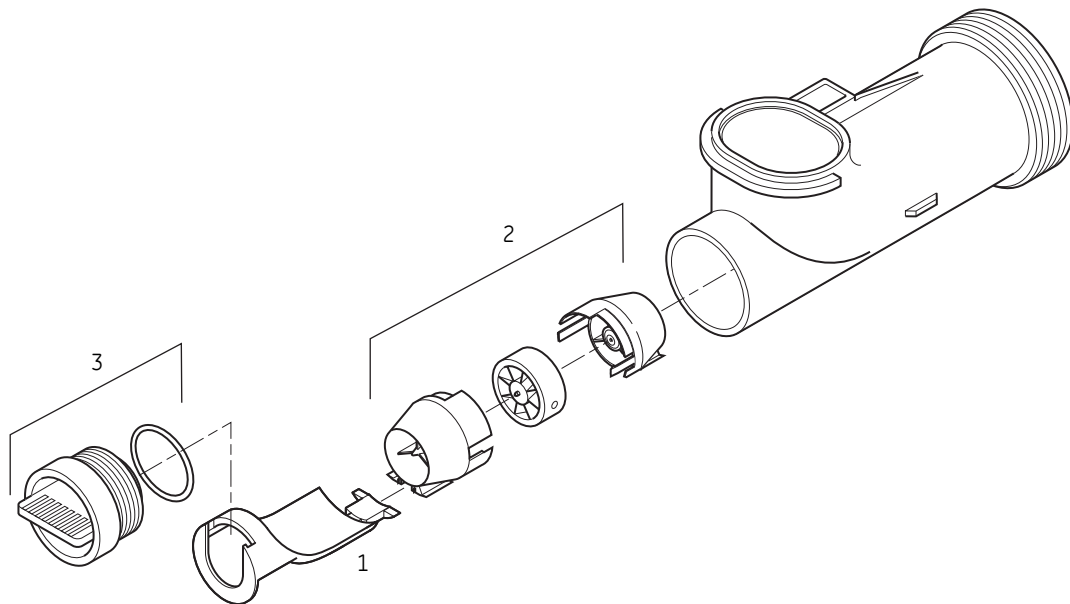

Item	Part Number	Description
1	1000074	Insert, Corner 2-inch
2	1232965	Assembly, Turbine 2-inch Elbow
3	1000318	Assembly, Cap

## 21.7 Installation Adapter Kits

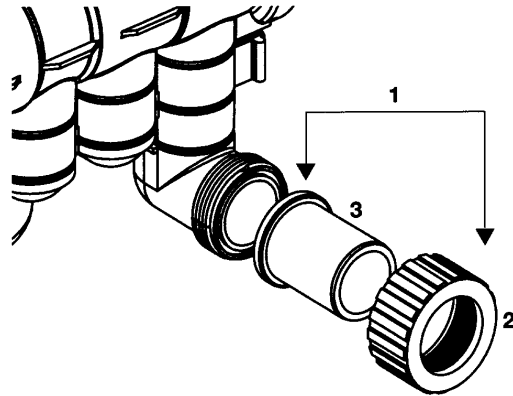

### Adapters- Magnum Cv

Item	Part Number	Description
Not Shown	1001657	Magnum Cv 1.5-inch Adapter Kit - Brass NPT for inlet, outlet, drain
Not Shown	1001658	Magnum Cv 1.5-inch Adapter Kit - Brass BSP for inlet, outlet, drain
1	1001655	Magnum Cv 1.5-inch Adapter Kit - CPVC for inlet, outlet, drain
Not Shown	1040544	1.5-inch NPT Brass Adapter with Glass Filled Noryl Nut (24 Pack)
Not Shown	1040555	1.5-inch BSP Brass Adapter with Glass Filled Noryl Nut (24 Pack)
1	1050556	1.5-inch CPVC Adapter with Glass Filled Noryl Nut (24 Pack)
2	1000356	Glass Filled Noryl Nut for 1.5-inch Adapter
Not Shown	1000360	1.5-inch Brass NPT Adapter
Not Shown	1000361	1.5-inch Brass BSP Adapter
3	1000358	1.5-inch CPVC Adapter
Not Shown	1001995	1-1/2-inch Brass NPT Adapter with Drilled and Tapped 1/4-inch NPT Port
Not Shown	1001996	1-1/2-inch Brass BSP Adapter with Drilled and Tapped 1/4-inch BSP Port

### Adapters-Magnum IT

Item	Part Number	Description
Not Shown	1040782	Magnum IT Adapter Kit - Brass NPT for inlet, outlet, drain
Not Shown	1040783	Magnum IT Adapter Kit - Brass BSP for inlet, outlet, drain
Not Shown	1040784	Magnum IT Adapter Kit - CPVC for inlet, outlet, drain
Not Shown	1040786	2-inch NPT Brass Adapter with Zinc Diecast Nut (24 Pack)
Not Shown	1040787	2-inch BSP Brass Adapter with Zinc Diecast Nut (24 Pack)
Not Shown	1040788	2-inch CPVC Adapter with Zinc Diecast Nut (24 Pack)
Not Shown	1030664	2-inch Cast Zinc Diecast Nut
Not Shown	1030663	2-inch Brass NPT Adapter
Not Shown	1033863	2-inch Brass NPT Adapter with Drilled and Tapped 1/4-inch NPT Port

---

---

<b>Item</b>	<b>Part Number</b>	<b>Description</b>
Not Shown	1030665	2-inch Brass BSP Adapter
Not Shown	1033864	2-inch Brass BSP Adapter with Drilled and Tapped 1/4-inch BSP Port
Not Shown	1030666	2-inch CPVC Adapter
Not Shown	1030667	63-mm Metric PVC Adapter
Not Shown	1002906	1.5-inch to 2-inch Brass Bell Reducer Coupling
Not Shown	1010160	1.5-inch Adapter O-Ring
Not Shown	1010165	2.0-inch Adapter O-Ring

## 21.8 Miscellaneous Kits and Assemblies

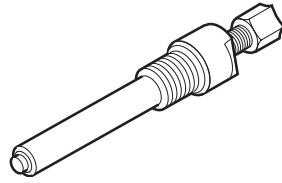

External Pilot Feed Adapter

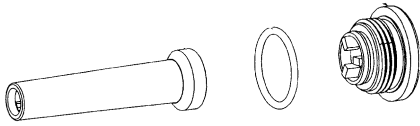

Pilot Filter Screen Assembly

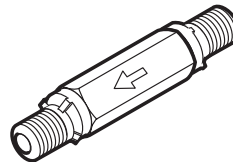

External Pilot System Check Valve

Part Number	Description
1000226	Pilot Screen Assembly (includes Pilot Screen, Pilot Screen Cap and O-ring)
1040691	Valve O-ring Kit (tank adapter O-ring, (3) O-rings for 1-1/2-inch inlet, outlet, drain and distributor O-ring)
1040692	Pilot Flapper Kit (pilot, brine and springs)
1040668	External Pilot Feed Adapter (separate source pilot water)
1009817	External Pilot System Check Valve
1000878	Outdoor Cover
1009115	Top Stacking Distributor
1005953	Top Plate Screws (15 req'd)
1006093	Top Plate Screws (5 req'd)
1010162	Tank Adapter O-ring
1010160	Riser Tube O-ring

